



***Helping our members work together
to keep the lights on...
today & in the future***

**SPP EIS
Market Training
Markets 301**



Contents

- Market Concepts
- Energy Imbalance – Defined
- Market Benefits
- Locational Imbalance Pricing
- Scheduling
- Native Load Scheduling
- Market Systems
- Load Forecast
- Resource Plans
- Ancillary Service Plans
- Offer Curves
- Dispatchable Range
- Deployment
- Market Timeline
- Uninstructed Resource Deviation
- Energy Schedules
- TLR & Congestion Management
- Net Scheduled Interchange
- SFTDA
- Supply Adequacy Analysis
- Settlements
- Market Monitoring
- Multiple Listeners



Student Objectives

- **Describe any resource status as used in the SPP Market**
- **Define Energy Imbalance**
- **Define Uninstructed Deviation**
- **Describe the timing used in the resource dispatch process**
- **Differentiate between a MP's Resource Plan, Ancillary Service Plan, and its Offer Curve.**
- **Describe the market activities timeline in regards to data submission.**
- **Describe the relationship between load requirements, pricing, and deployment instructions**
- **Describe the relationship between market dispatch and constraint management.**



Markets 301

El Market Overview



Market Concepts – What is a Market?

- **General Concept**
 - An interaction between buyers and sellers
 - An energy market exists when competing generators/suppliers offer their electricity output to customers
- **RTO Facilitated Market**
 - Spot energy market required by FERC
 - Allows participants to offer resources into the market
 - Designed to promote use of least cost generation for Imbalance
 - SPP oversees the activities of the market, insuring reliability, forecasting supply requirements and providing Market Monitoring oversight



SPP EIS Market Highlights

- **All Load and resources (more than 10 MW) within the SPP Market are subject to financial settlement of Imbalance Energy.**
- **The financial impact on both resources and load is within the “control” of the participants through the use of energy schedules.**
- **Hourly imbalance settlement for both load and resources are netted prior to invoicing.**
- **Dispatch is regional and is calculated using a security constrained, offer-based economic dispatch (SCED) every 5 minutes.**



SPP EIS Market Highlights

- **Dispatch is regional and is calculated using a security constrained, offer-based economic dispatch (SCED) every 5 minutes.**
 - **If a resource is Self-dispatched, it is still subject to imbalance settlement if actual output does not match scheduled output.**
 - **Any resource that is offered for SPP dispatch has the entire asset subject to dispatch (within the "Dispatchable Range").**

Entity Relationships

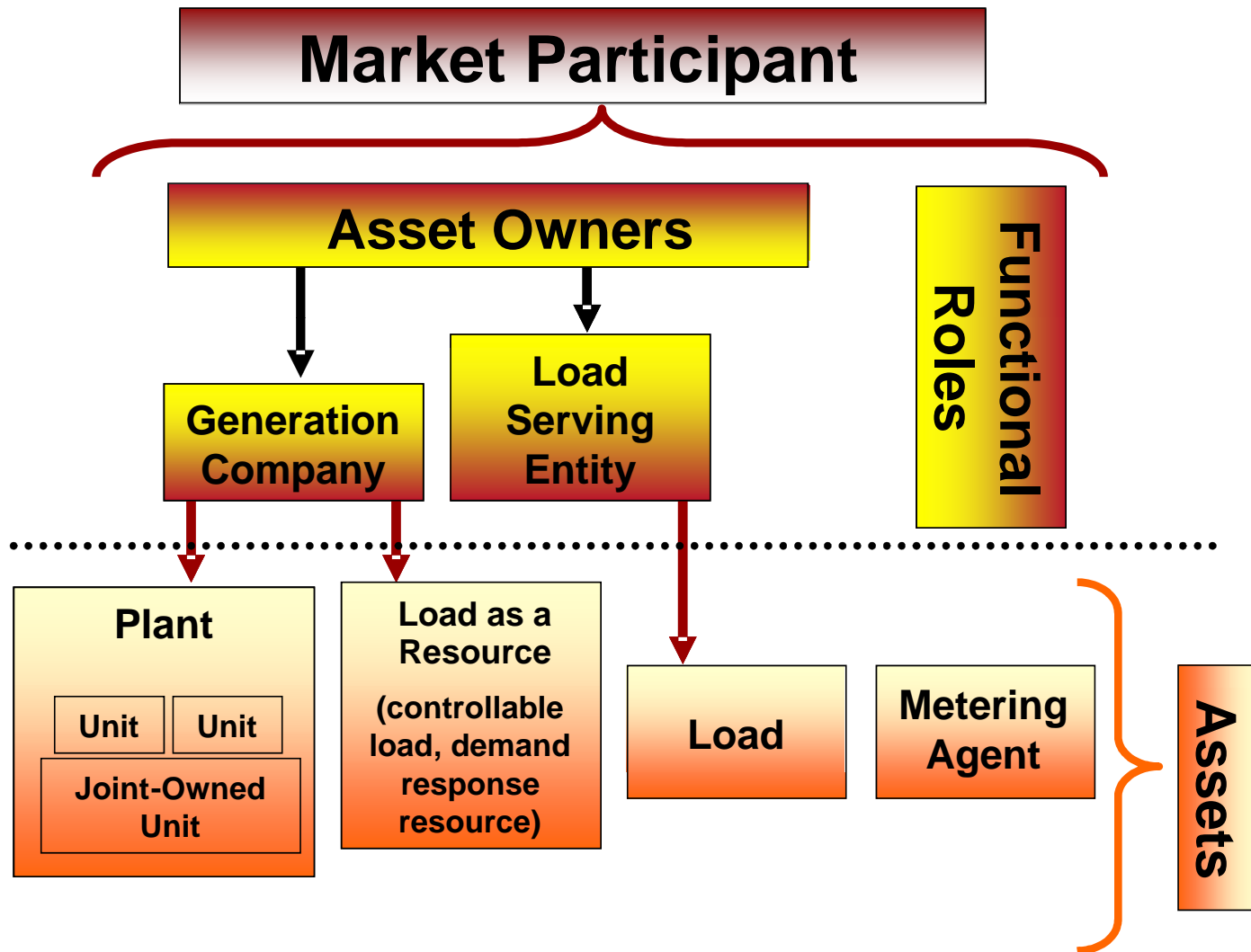



Entity Relationships

- **A Market Participant (MP) is the only entity that has a legal and financial obligation to SPP in the market.**
 - **For submitting resource plans related to assets**
 - **For submitting ancillary service capacity plans (Up and Down Regulation and Spinning/Supplemental reserves)**
 - **For submitting offer curves related to assets (prices per MW output)**
 - **For submitting load forecasts (BA and MP)**
 - **For schedules and settlements**



Entity Relationships

Asset Owners include:

- **Generation Companies (GenCos)**
 - They own resource assets that are scheduled and settled on a nodal basis
 - Submit and receive data from the market system at the nodal level (assets include generators, plants, and loads)
- **Load Serving Entities (LSE)**
 - They own load assets that are scheduled and settled zonally or nodally, based on the decision of the LSE
 - Submit and receive data from the market system zonally or nodally
- **Metering Agent (MA)**
 - Submit actual meter data for assets they are registered to represent



What are the Market Protocols?

- **An evolving document that defines:**



1. **Terms of the SPP Market**
 2. **Procedures for the SPP Market**
 3. **Responsibilities of MP (Market Participant)**
 4. **Responsibilities of SPP**
 5. **Energy Obligations of the MP and SPP**
- **Changes are through various working groups**
 - **Approved by MOPC (Market Operations Policy Committee)**



Markets 301

Energy Imbalance Service (EIS)



What is the “SPP Energy Imbalance Service” Market?

- **The SPP EIS Market provides asset owners the infrastructure necessary to offer their resources into the marketplace for use in providing Energy Imbalance.**
- **In the EIS marketplace, SPP owns the responsibility of accounting for and financially settling all EIS amounts.**
 - **SPP will remain revenue neutral**



What is the “SPP Energy Imbalance Service” Market?

- **The SPP EIS market does not supersede any MP’s obligations with respect to any other capacity or ancillary service obligations.**
 - **Balancing Authorities (BA) and asset owners will continue to use the same procedures used today to manage capacity adequacy, reserves, and other reliability-based concerns.**
- **All MPs with load and/or resources within the SPP Market footprint will be subject to EIS under this market.**
- **All asset owners must register with the SPP EIS market.**



What is “Imbalance Energy”?

- **Imbalance energy (Energy Imbalance, or EI) is the difference between what actually happens for each generator and load location, and what they prearranged through schedules.**
 - **Generators produce amounts different than they schedule**
 - **Loads consume amounts different than they schedule**

Energy Imbalance = Actual Production or Usage – Scheduled Production or Usage

$$\mathbf{EI = A - S}$$

- **The amount of increase or decrease in generation is paid for by the asset owner needing the energy.**



What is the “Energy Imbalance Service”?

- **EIS is the dollar amount associated with the imbalance energy.**
- **EIS is calculated by taking the amount of EI and multiplying it by the price at a specific point on the energy grid (LIP).**

**Energy Imbalance Service = Imbalance Energy x
Locational Imbalance Price (LIP)**

$$\mathbf{EIS = EI \times LIP}$$

Imbalance Energy Example

Imbalance (Gen A) = (-90 MWh Actual) – (-100 MWh Scheduled)

Imbalance (Gen A) = 10 MWh

Imbalance (Load B) = (90 MWh Actual) – (100 MWh Scheduled)

Imbalance (Load B) = -10MWh

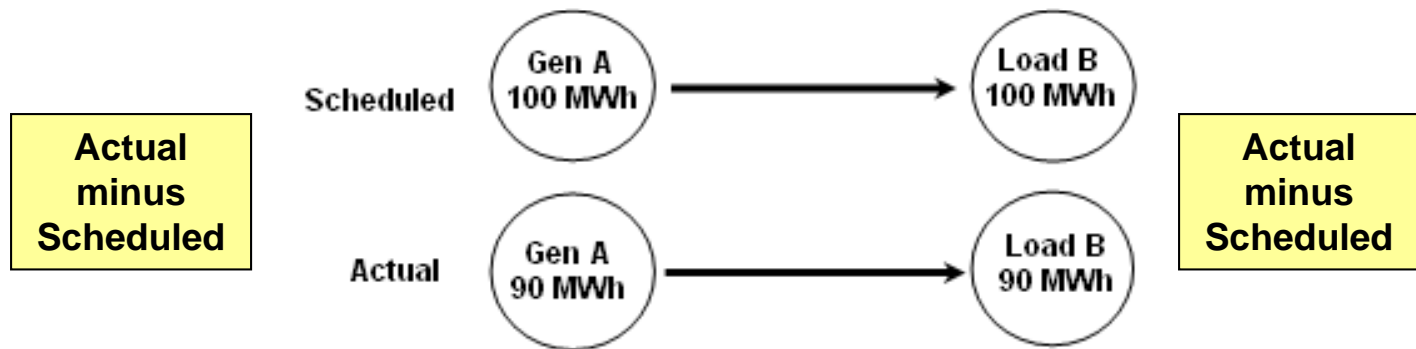

Note: Generation Injections are (-) and Load Withdrawals are (+) as viewed from an SPP settlement reference frame for EIS.

Notice that even though the *system* was in balance (generation matched load), by definition there was an imbalance at each location. Actual and Scheduled were not equal.



Quick Quiz Question



Actual Energy minus Scheduled Energy equals what SPP Market term?

If the above answer is multiplied by an Imbalance Price, this would be referred to as...



Markets 301

Market Benefits



Benefits of the SPP EIS Market

- **Asset owners benefit from pooling their resources and gaining access to lower, more transparent pricing.**
 - **GenCos benefit by having the option of reducing their generation and buying lower cost energy from the SPP market to serve their load, and by offering their generation into the marketplace for exposure to an increased customer base.**
 - **GenCos are also able to more closely operate to their economical efficiency point.**
 - **LSEs benefit from more efficient competition among suppliers (generators) which should lower spot energy prices.**

Example 1: No Market Participation

- **GenA has a bilateral contract with Load A and schedules 200 MWh at \$40/MWh to Load A.**
- **GenB has made no arrangements for sales and has no schedule**
- **It costs GenA \$30/MWh to produce the energy.**
- **Generator A has a profit of:**

$$(\$40/\text{MWh} - \$30/\text{MWh}) \times 200 \text{ MWh} = \$2,000$$

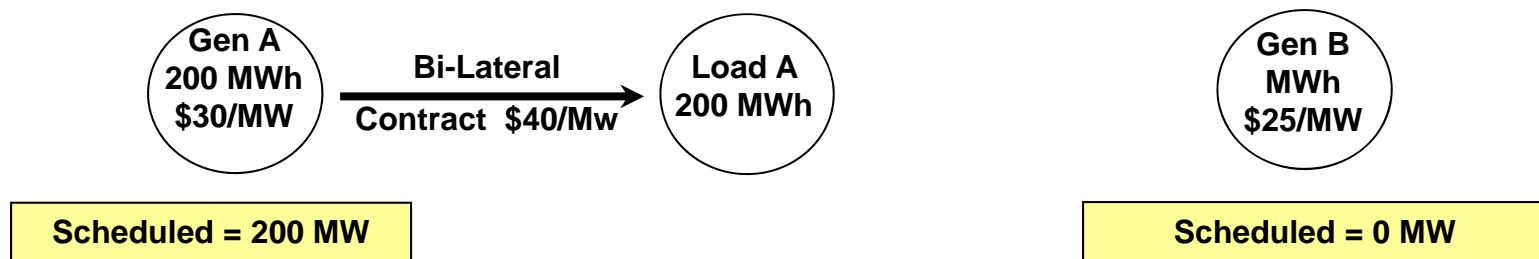

Example 1: Market Participation

- Aside from GenA's contract, GenA also decides to offer its generation into the SPP market @ \$30/MWh.
- GenB decides to participate as well by offering its resource as an "Available" resource
- The SPP Market recognizes it can supply load @ \$25/MWh based on offers by these two participants.
- Therefore, SPP instructs GenA to go to Min Econ MW (10 MW) because its price is higher than the LIP.

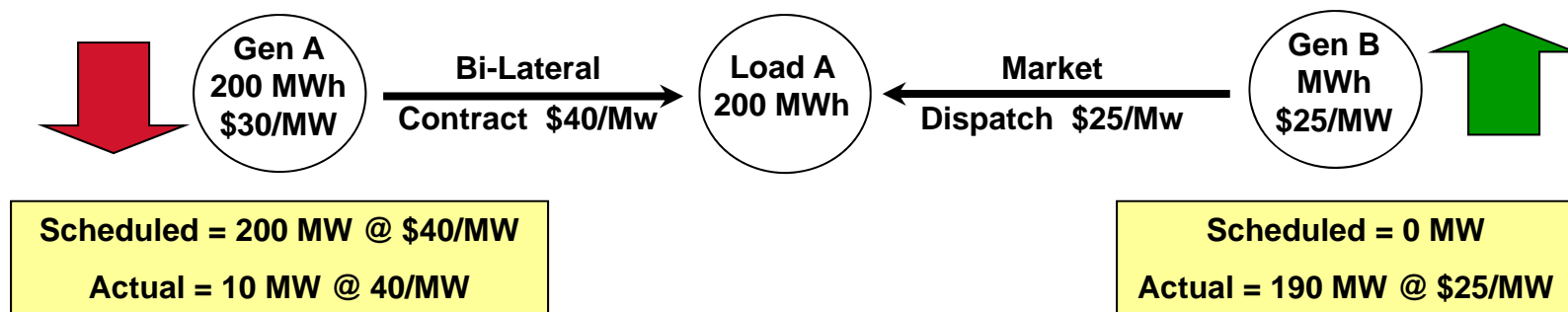

Example 1: Market Participation

Gen A EIS = (Actual – Scheduled) x LIP

Gen A EIS = [-10 MWh – (-200 MWh)] x \$25/MWh

Gen A EIS = 190 MWh x \$25/MWh

Gen A EIS = \$4,750 (Paid to SPP)



GenA pays SPP \$4,750

SPP will disperse this money to the generator(s) that actually provided the 190 MW of energy.

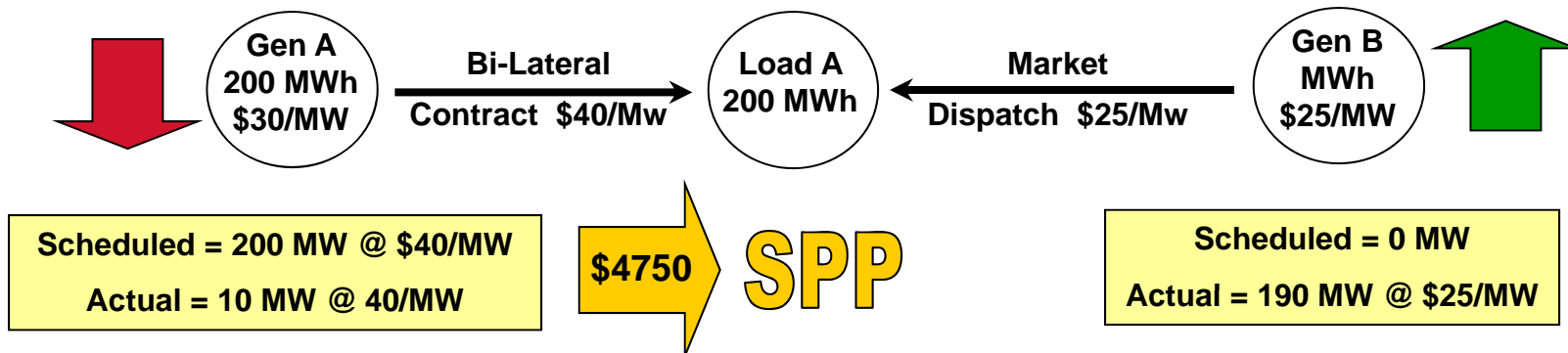

Example 1: Market Participation

Gen B EIS = (Actual – Scheduled) x LIP

Gen B EIS = [-190 MWh – (0 MWh)] x \$25/MWh

Gen B EIS = -190 MWh x \$25/MWh

Gen B EIS = - \$4,750 (paid to this resource)

A negative value

SPP pays Gen B \$4,750

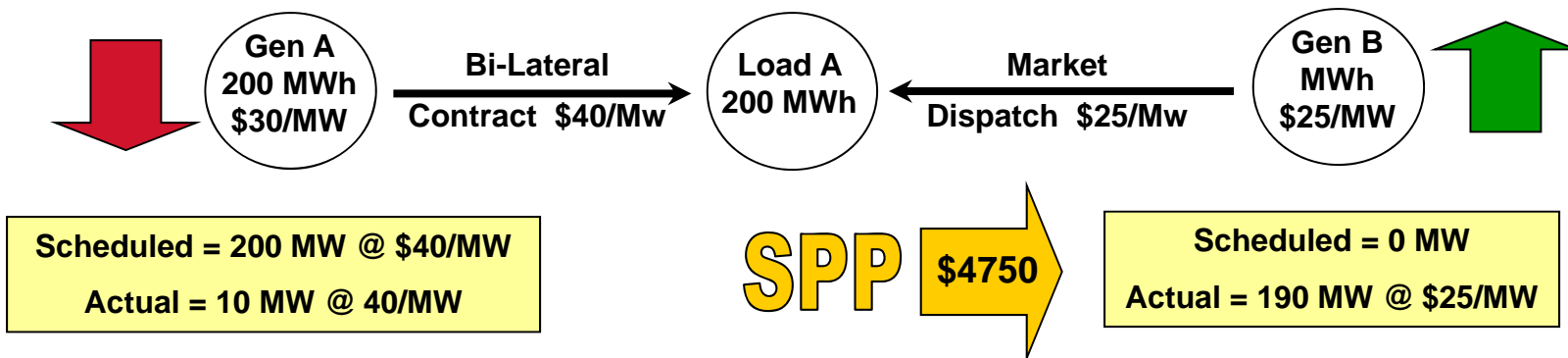

Example 1: Market Participation

Load A EIS = (Actual – Scheduled) x LIP

Load A EIS = (200 MWh – 200 MWh) x \$25/MWh

Load A EIS = 0 MWh x \$25/MWh

Load A EIS = \$0

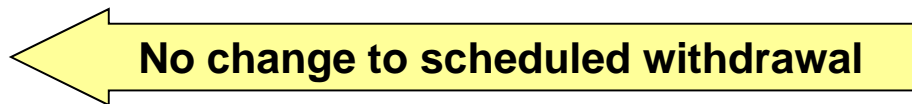

Load A pays no EIS

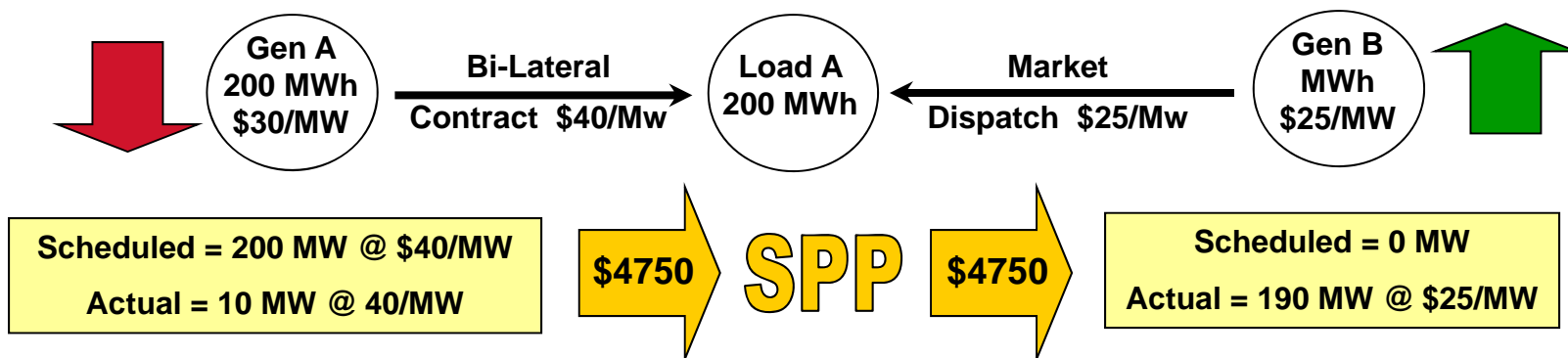

Example 1: Market Participation

- GenA paid SPP \$4,750 in lieu of spending \$5,700 to generate the 190 MWh of energy itself.
- This saved GenA \$950 by offering the resource to the Market
- GenA continues to receive compensation from load A under its bilateral agreement (200MWh x \$40/MWh) of \$8000.
- GenA profits increased from \$2000, to \$2950
- GenB was allowed to use otherwise unused capacity

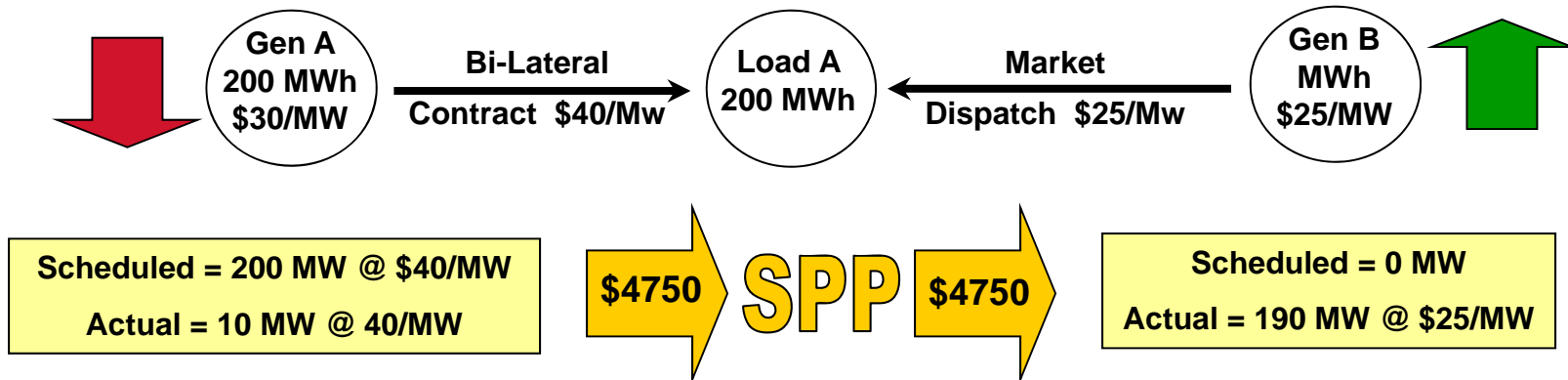



Quick Quiz Question



Scenario

- Generator A sells 60 MW of power to Load B for 1 hour at \$50/MWH and enters a schedule for that amount
- Generator A's average cost of production is \$30/MWH
- Generator A offers 60 MW into the market at \$30/MWH
 1. Min MW=20, Max MW=60

Questions

1. If the LIP is \$100, what is the generator's net profit including EIS settlements? What is the cost to the load?
2. How does the answer to (1) above change if the LIP is \$20 instead of \$100?





Markets 301

Locational Imbalance Pricing (LIP)



Pricing

A resource that is not free to change output to move along its offer curve in response to SPP's dispatch will not set price

❖ Resource status that does set LIP price

- Available

❖ Resource status that does not set LIP price

- Self Dispatched
- Manual
- Unavailable
- Supplemental



Pricing Imbalance Energy in an Unconstrained & Constrained System

- **Imbalance energy is priced depending on which resources are deployed to meet the load requirements. This is known as Locational Imbalance Pricing or LIP.**
 - An unconstrained system will have a single system wide price, or a **System Marginal Price (SMP)**.
- **LIP recognizes that cost may vary at different times and locations based on real-time system conditions.**
 - Constraints on the system can cause price divergence among the various nodes due to the out-of-order dispatch needed to prevent operating limit violations.
- **With LIP, asset owners know the price per MWh of electricity at various intersections on the system (nodes).**



Locational Imbalance Price (Unconstrained)

- **Here's an example...**

Generator A offers 10 MW @ \$15/MWh

Generator B offers 10 MW @ \$20/MWh

Generator C offers 10 MW @ \$30/MWh

SMP

- **To supply 15 MWh of energy to a load in an unconstrained system, the market selects the most economical generation within current reliability standards. In this case, Generators A and B.**

Generator A 10 MW @ \$15/MWh

Generator B 5 MW @ \$20/MWh (sets price as providing the “next” increment of energy)

- **In this case, Generators A and B would both get paid \$20/MWh for their participation in serving the 15 MW load**

Post-Market Energy Imbalance Process

- **But what if it is impossible to deliver power economically within current reliability standards?**
- **Binding constraints (preventing a limit violation) usually result in:**
 - **Generation being dispatched out of economic order**
 - **Different prices for energy at different points in the system (or price divergence)**
- **When there are constraint violations, action must be taken to maintain reliability standards.**

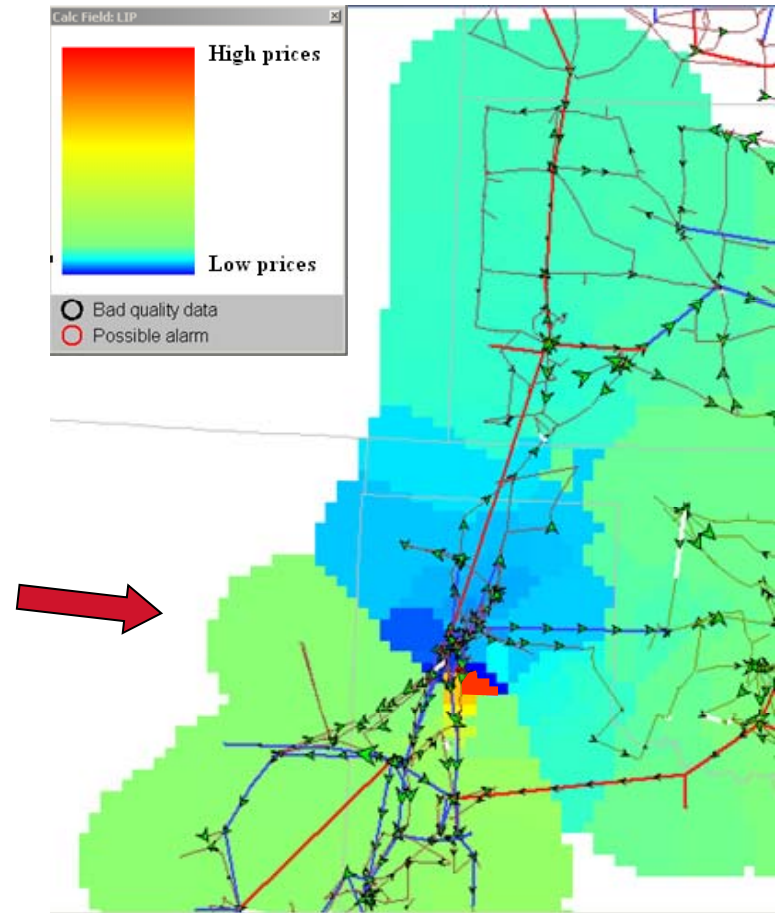



Settling an Imbalance Financially

- **Suppose the following:**

LIP @ (Gen A) = \$30/MWh

LIP @ (Load B) = \$40/MWh

The resulting charges would be:

EIS (Gen A) = \$30/MWh x 10 MWh = \$300 (MP pays SPP)

EIS (Load B) = \$40/MWh x -10 MWh = -\$400 (SPP pays MP)

NOTE: A (+) EIS indicates that SPP will receive payment from the Participant (a charge)
A (-) EIS indicates that SPP will pay out to the Participant (a credit)

- **The net imbalance is zero (generation equaled load), but there is a net payment of \$100 (\$300+(-\$400)) to Load B because of different prices at different points in the system.**



Quick Quiz Question



An unconstrained system would have the same price at every node.

True or False?



Accessing LIP

- **Market Participants can access the LIP in three ways:**
 - Portal (real-time)
 - SPP.org (OH+15 minutes)
 - Application Programmatic Interface (API)
- **In summary, LIP ensures:**
 - Consistency between market prices and reliability dispatch.
 - That the dispatch is more accurate than only curtailing multiple transactions to relieve transmission loading.

LIP: The “Supply” Curve

- The supply curve is an aggregation of all MP offer curves in the SPP footprint.
- The following graph is an example of the aggregation of two resource offer curves.

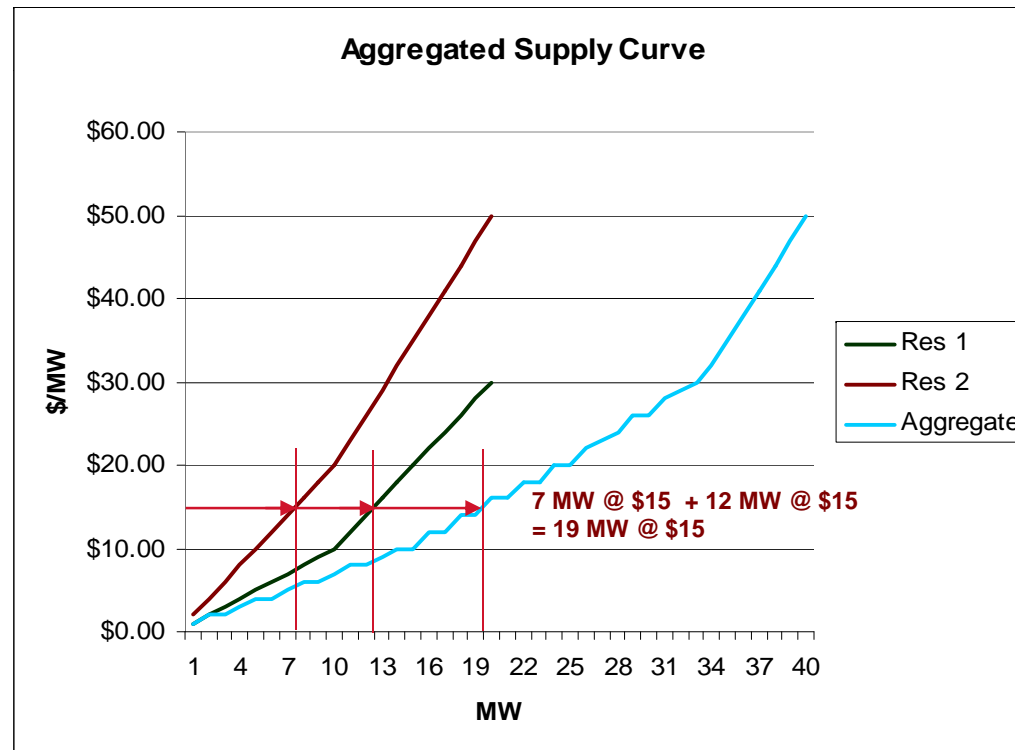

LIP: The “Demand” Curve

- **SPP’s forecasted market load for the entire footprint, adjusted for:**
 - **Self-dispatched generation (subtraction).**
 - **Net Market footprint interchange.**
- **Demand is assumed to be completely independent of price.**

Example:

$$\text{FML} = 20,000\text{MW} - 2,000\text{MW} - 1,500\text{MW} + 2,500\text{MW}$$

Forecasted Market Load = Forecasted load - Self-dispatch – Imports + Exports

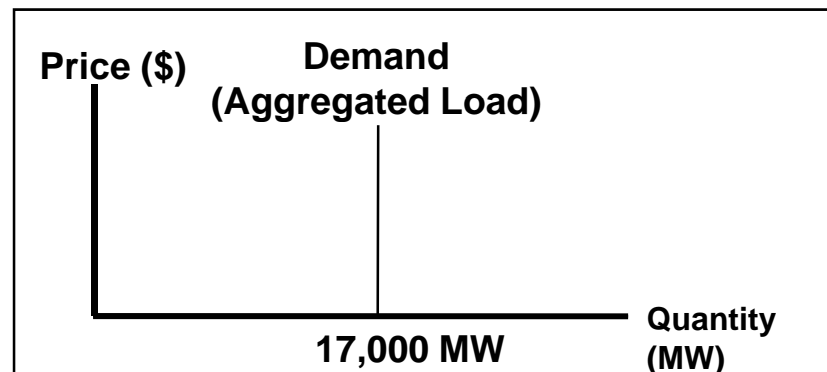



Supply and Demand Put Together

- Demand (aggregated load) intersects with supply (aggregated offer curves) to derive the market clearing price.
- This assumes an unconstrained system.

Quick Quiz Question



How much aggregated load could be served with this aggregated supply without exceeding \$30 per MW?

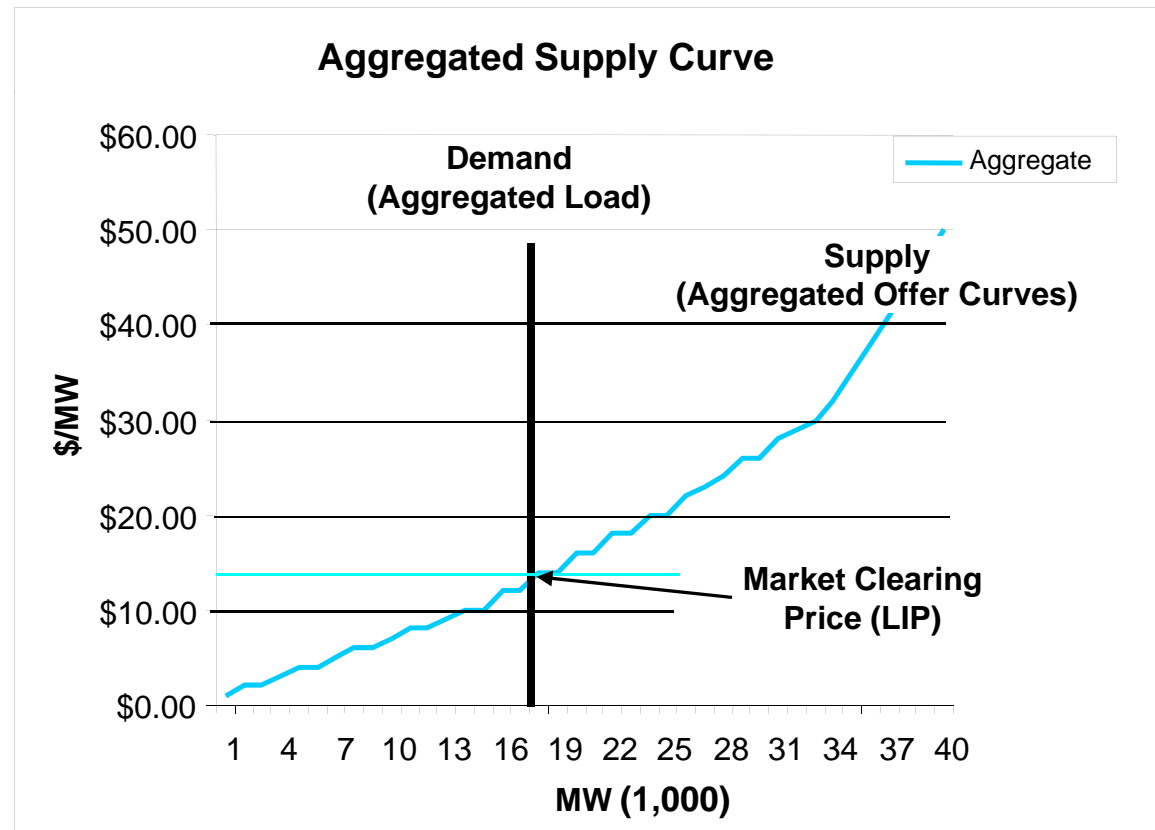



Quick Quiz Question



An SPP Market “Available” resource is dispatched to its MaxMW, but is never dispatched to serve the “next” incremental MW. Does this resource still set price?



Markets 301

Scheduling



Energy Schedules

- **Used in the SPP contingency analysis, determining generation needs, and calculating NSI**
 - **Submitted by MP to reflect Market, Bilateral and Self-dispatch activities**
 - **No later than OH-30 minutes for tag submission**
 - **No later than OH-20 for Native Load Schedules**



Native Load Schedules

A Native Load Schedule is one that:

- **Sources within your BA (designated resource)**
- **Sinks within your BA (load settlement location)**
- **Obligates one of your (Market Participant) specific resources**



RSS (Reserve Sharing System) Schedules

- **Schedules are created for RSS deployments**
- **Treated as a bilateral Market schedules**
- **Based upon resources identified as carrying Spin and Supp Reserves**
- **Actual schedule can be submitted no later than 0100 three days after the RSS event OH**



SCHEDULES & TAGS

SCHEDULE:

- **An agreed-upon interchange Transaction size (Mw), start and end time, beginning and ending ramp times and rate, and type required for delivery and receipt of power and energy between the Source and Sink Balancing Authorities involved in the transaction.**

TAG:

- **The details of an Interchange Transaction required for its physical implementation.**



What is RTO_SS?

- **The acronym “RTO_SS” stands for Regional Transmission Organization Scheduling System.**
- **SPP’s electronic scheduling system - created by the SPP Scheduling Task Force**
- **Based on OATI’s webScheduler and tagging products.**
- **Official Definition:**
 - **RTO_SS provides an electronic mechanism for approval and coordination of schedules among the parties of a transaction.**



Markets 301

Native Load Scheduling (NLS)

Native Load Schedules Carrying Your Own Load





Native Load Schedules - Carrying Your Own Load

A Native Load Schedule is one that:

- Sources within your BA (designated resource)
- Sinks within your BA (load settlement location)
- Obligates one of your (Market Participant) specific resources



Native Load Schedules - Carrying Your Own Load

A few things to keep in mind about NLS...

- NLS do not use NERC tags –
 - they don't cross Interchange boundaries
- NLS do not require a Reservation Number
 - covered under NITS reservations
- NLS will be automatically approved through RTO_SS
 - if MP has met requirements for NITS Service



Native Load Schedules - Carrying Your Own Load

The Theory of NLS:

Market participants typically desire to schedule from each of their generators to their loads to avoid price exposure. (see the following examples)



Example without Schedules

- **Gen A has no schedules. It submitted a Resource Plan for 200MW at \$30/MW in Available status to the EIS Market.**
- **Load A has no schedules.**
- **At the end of the hour, Gen A was deployed to its max of 200MW, Load A consumed 200MW as planned.**
- **The LIP at Gen A was \$35 and the LIP at Load A was \$55 due to congestion.**

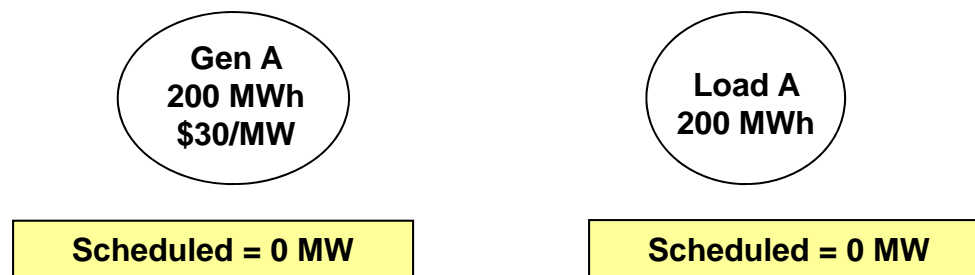



Example without Schedules

$$\text{Gen A EIS} = (\text{Actual} - \text{Scheduled}) \times \text{LIP}$$

$$\text{Gen A EIS} = [-200\text{MWh} - (0 \text{ MWh})] \times \$35/\text{MWh}$$

$$\text{Gen A EIS} = -200 \text{ MWh} \times \$35/\text{MWh}$$

$$\text{Gen A EIS} = \text{\$-7000 (SPP Pays Gen A)}$$

$$\text{Load A EIS} = (\text{Actual} - \text{Scheduled}) \times \text{LIP}$$

$$\text{Load A EIS} = [200\text{MWh} - (0 \text{ MWh})] \times \$55/\text{MWh}$$

$$\text{Load A EIS} = 200 \text{ MWh} \times \$55/\text{MWh}$$

$$\text{Load A EIS} = \text{\$11,000 (Load Pays SPP)}$$

In summary,
Company "A" pays
SPP \$4,000 as a result
of exposure to price
separation due to
congestion.



Example with Native Load Schedule

- **Gen A has a Native Load Schedule sinking at Load A. It also submitted a Resource Plan for 200MW at \$30/MW in Available status to the EIS Market.**
- **Load A has a Native Load Schedule sourced from Gen A**
- **At the end of the hour, Gen A was deployed to its max of 200MW, Load A consumed 200MW as planned.**
- **The LIP at Gen A was \$35 and the LIP at Load A was \$55 due to congestion.**

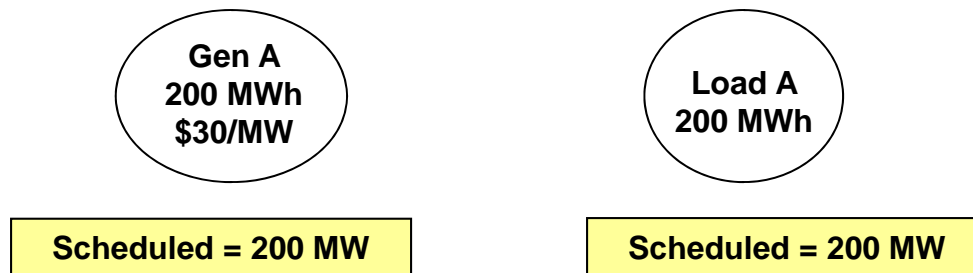



Example with Schedules

Gen A EIS = (Actual – Scheduled) x LIP

Gen A EIS = [-200MWh – (-200 MWh)] x \$35/MWh

Gen A EIS = 0 MWh x \$35/MWh

Gen A EIS = \$0 (SPP Pays Gen A)

Load A EIS = (Actual – Scheduled) x LIP

Load A EIS = [200MWh – (200 MWh)] x \$55/MWh

Load A EIS = 0 MWh x \$55/MWh

Load A EIS = \$0 (Load Pays SPP)

In summary,
Company owes SPP
nothing because it
“carried it’s own load”
by being fully hedged
with NLS.



Native Load Scheduling (NLS) Theory vs. Practice



Native Load Schedules - Carrying Your Own Load

Review

The Theory of NLS:

Market participants typically desire to schedule from each of their generators to their loads to avoid price exposure. (see the following examples)



The Practice of NLS: Background

- **SPP Market Participants (MPs) have the ability to enter Native Load Schedules into SPP’s Native Load System for schedules between Resource and Load Settlement Locations (LSL) in the same Balancing Authority.**
- **Many MPs have found it beneficial to use NLS to over-schedule generation to their LSL and then enter tagged BA-to-BA schedules sourced from their load (see example on next slide).**
- **The tagged BA-to-BA schedules are sometimes referred to as “Portfolio Sales”; or are also called Off-System sales, Bilateral schedules, exports, and others.**

Example of NLS in "practice"

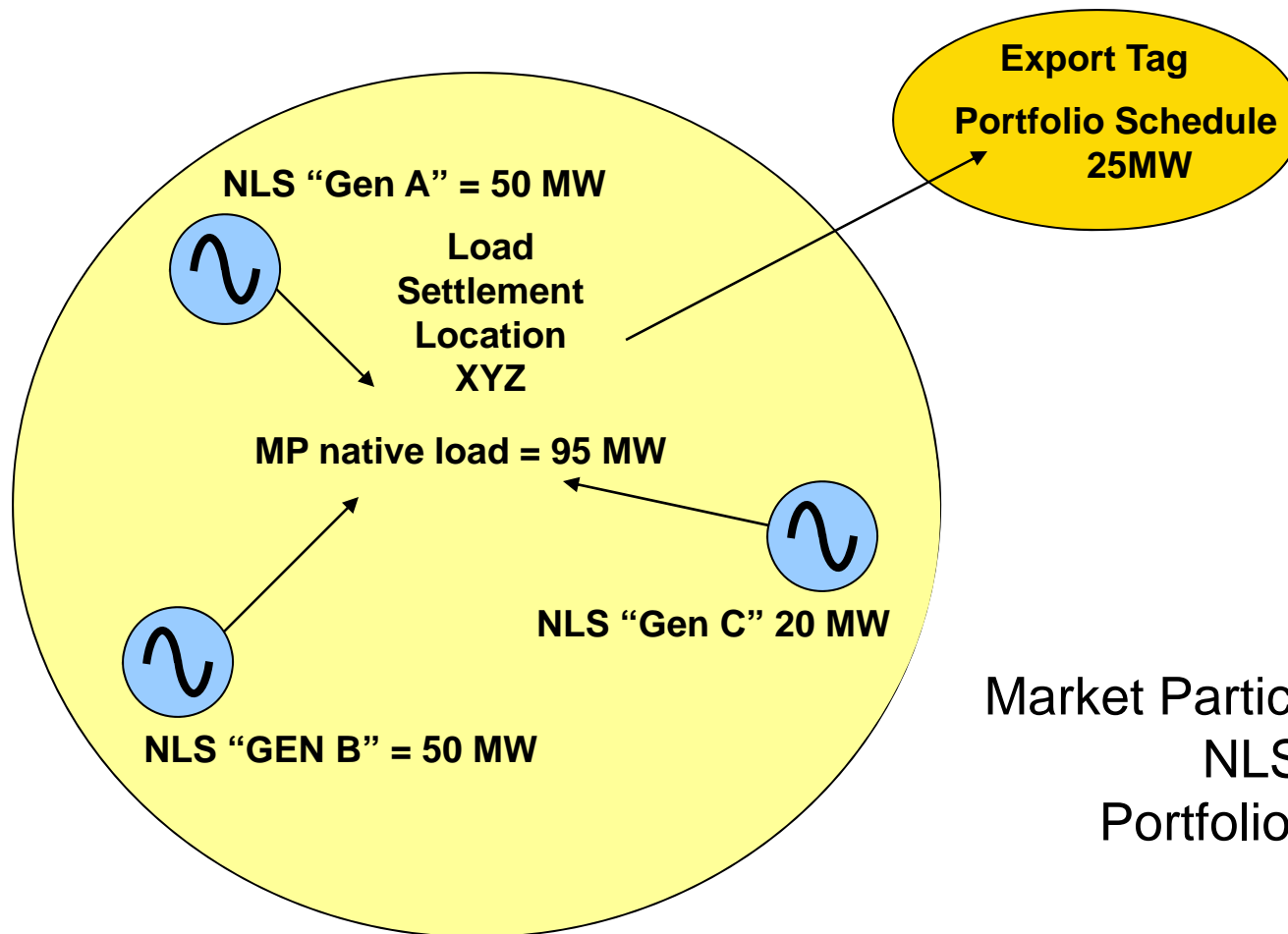

Market Participant Load = 95 MW
 NLS = 120 MW
 Portfolio Sales = 25 MW



Native Load and Portfolio Scheduling (NLPS)

- **The SPP Market Monitoring Unit (MMU) recognized this MP trend of using NLS to serve bilateral schedules, and raised concerns about not being able to differentiate between those NLS schedules serving Native Load (NITS) and those used to support Portfolio schedules.**
- **In November 2009, SPP implemented the new Native Load & Portfolio Schedule (NLPS) tool to help differentiate between Native Load Schedules and Portfolio sales**
- **NLPS is the RTO_SS schedule type used for native load schedules**
- **Other schedule types (listed below) provide differentiation of the NLPS amount being used for native load and for portfolio sales.**
 - **NLPRA schedule – indicates portion NLPS used for portfolio**
 - **NITS schedule – indicates portion of NLPS used for native load**

Example with NLPS

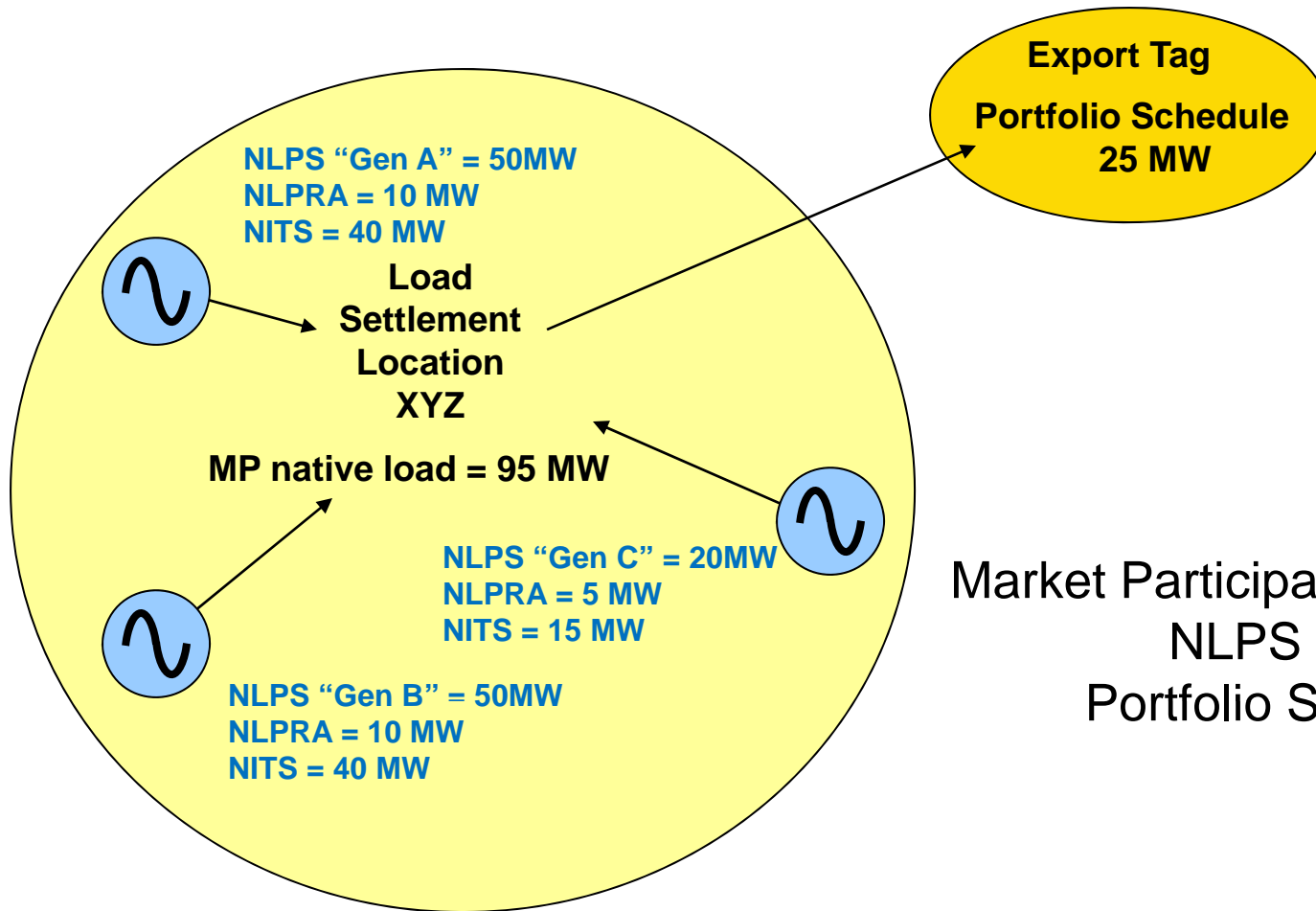

Market Participant Load (NITS) = 95
 NLPS = 120 MW
 Portfolio Sales = 25 MW



Markets 301

Market Systems

Market Systems

Two Main Components

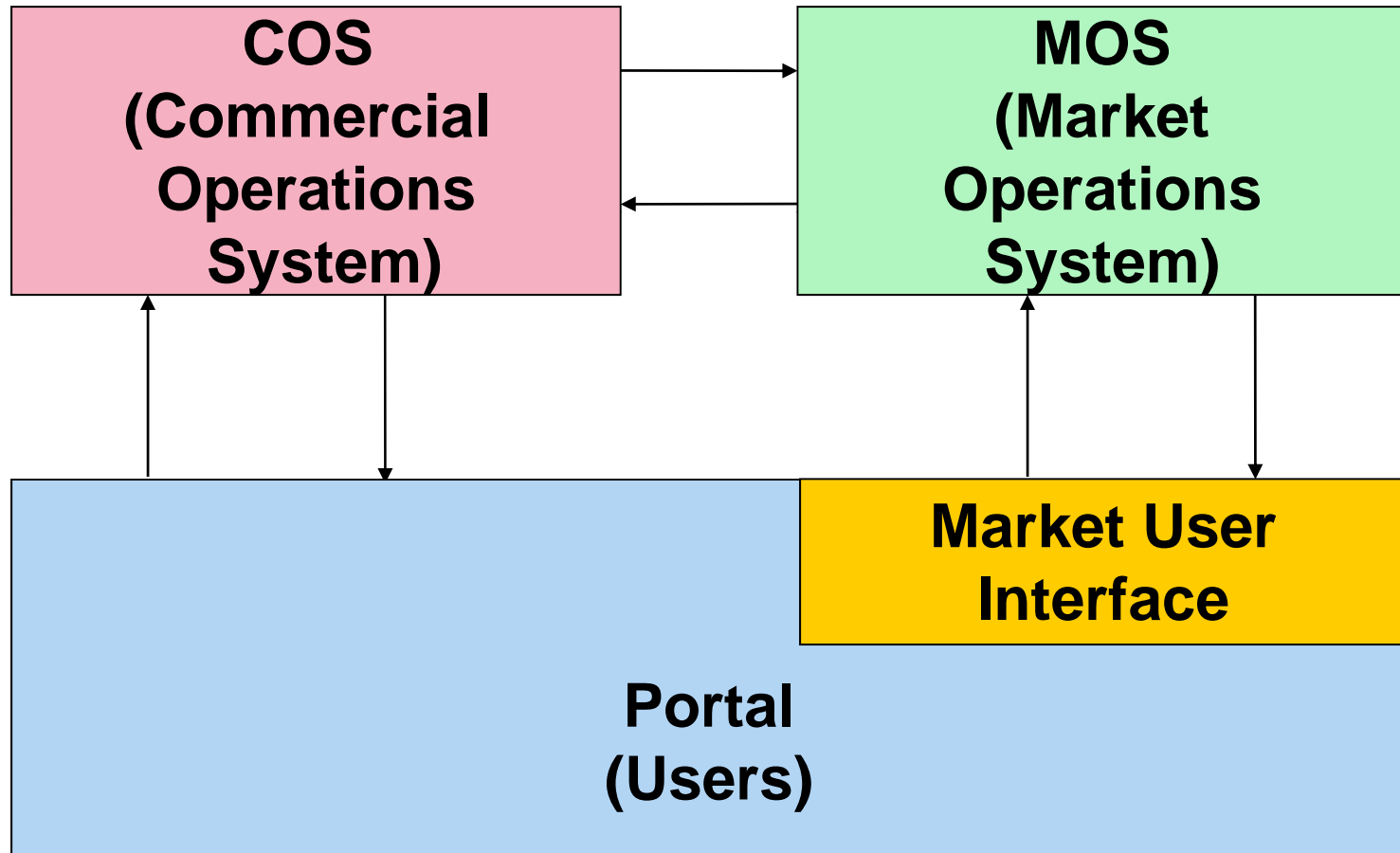



Portal

- **Web-based interface for users**
 - **Upload or query Metering Data**
 - **Accept meter actual submissions**
 - **Query Meter Data by Operating Date**
 - **Meter Agent ability to upload/view meter data**
 - **Access user “roles” (privileges)**
 - **View settlement statements by operating day**
 - **Submit Hourly MP Market data**
 - **Query MP Operationally important Market data**



Portal (cont.)

- **Web-based interface for users**
 - **Download Settlement Statements and Summaries**
 - **Download Entity Relationship Model Data (ERM)**
 - **Receive Notifications from SPP**
 - **Track service requests**
 1. **Changes in registration information**
 2. **Disputes with settlement statements**



Commercial Operation System (COS)

- **Receives and validates settlement data submissions (e.g., meter actuals)**
- **Stores commercial data**
 - **Customer information**
 - **Settlement locations, etc**



Market Operations System (MOS)

- **Performs security constrained economic dispatch (SCED)**
 - **User-submitted offer curves are used in providing the most economic dispatch without violating constraint**
- **Generates set-point instructions for each resource (a.k.a. base point, deployment, dispatch)**
- **Computes nodal price for each pricing node**
 - **Generator or load location**
- **Analyzes the A/S Capacity Plan, Resource Plan, and Offer Curves**



Market User Interface (MUI)

- **Provides Interactive Screens to the Portal including:**
 - **Resource Plan**
 - **Ancillary Service Plan**
 - **Offer Information**
 - **Dispatch Information**
 - **Load Forecast**
- **Provides Application Programmatic Interface (API) for automated data submission**



High Level SPP Systems Interactions

- **If we examine the systems interactions from a time perspective, they generally fall into three categories:**
 - **Day prior to operating day activities**
 - **Operating day market activities**
 1. **Hour ahead and operating hour market activities**
 2. **Post operating hour market activities**
 - **Post operating day activities**

SPP Systems Interaction

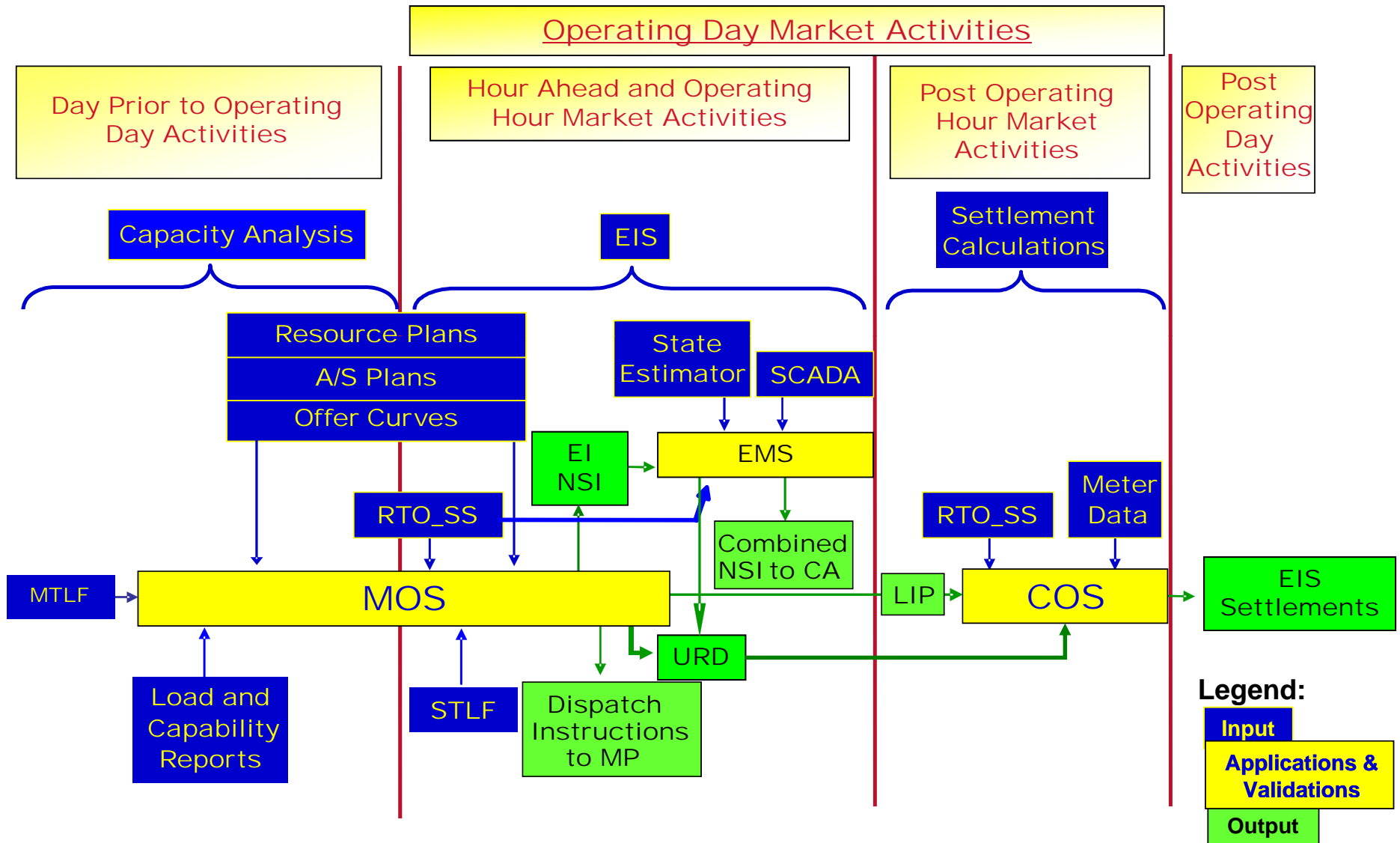



Quick Quiz Question



Which SPP Market system is used to deal with settlements?

MOS or COS?



Markets 301

Load Forecasting



Load Forecast

- **Purpose of the Load Forecast**
 - **Determine amount of resources necessary for the Market**
 - **Provide a Market flow estimate on flowgates**
 - **Determine supply adequacy (sufficiency)**
 - **Use in the SFT (Simultaneous Feasibility Test)**

How much Generation is needed?

And how much flow will exist?

Does the RP support this?

Will this Gen/Load combination create constraints?



Introduction to Load Forecasting

- **SPP generates its own independent load forecast consisting of:**
 - **Mid-Term Load Forecasts (MTLF) - used for reliability analysis**

Hourly for 7 days

- **Short-Term Load Forecasts (STLF) - used to determine SPP's total energy needs**

5 minute increments for 60 minutes



Introduction to Load Forecasting

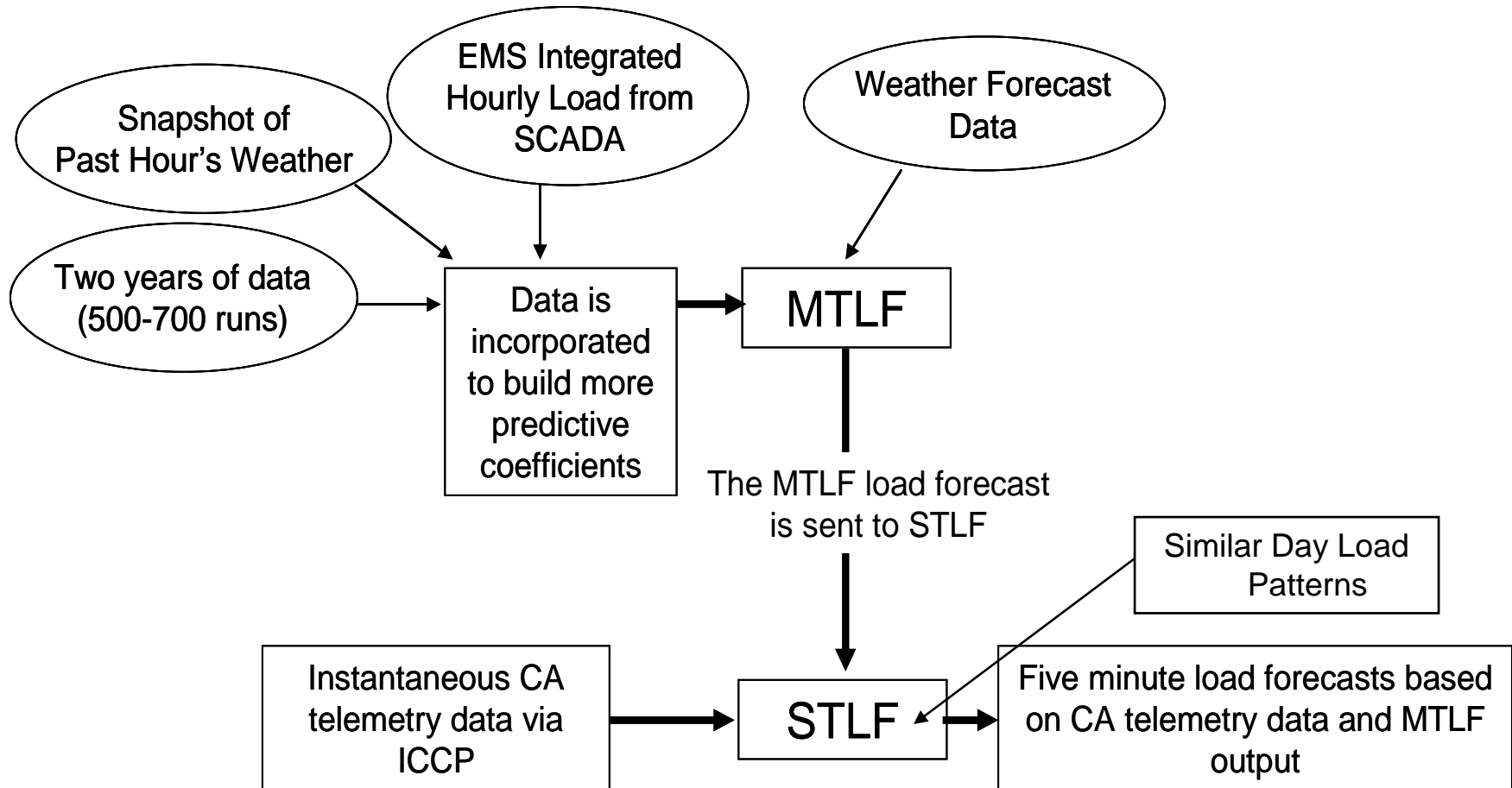



Hourly MP-Level Load Forecast

- **Used along with the Resource Plan and Ancillary Service Capacity Plan to indicate capacity deficiencies and available energy.**
- **Supports Resource Over/Under Commitment Calculations**
- **Submission Timing - May be submitted up to seven days prior to the Operating Day (OD)**
- **Update Timing - Up to 45 Minutes Prior to the top of the Operating Hour (OH)**

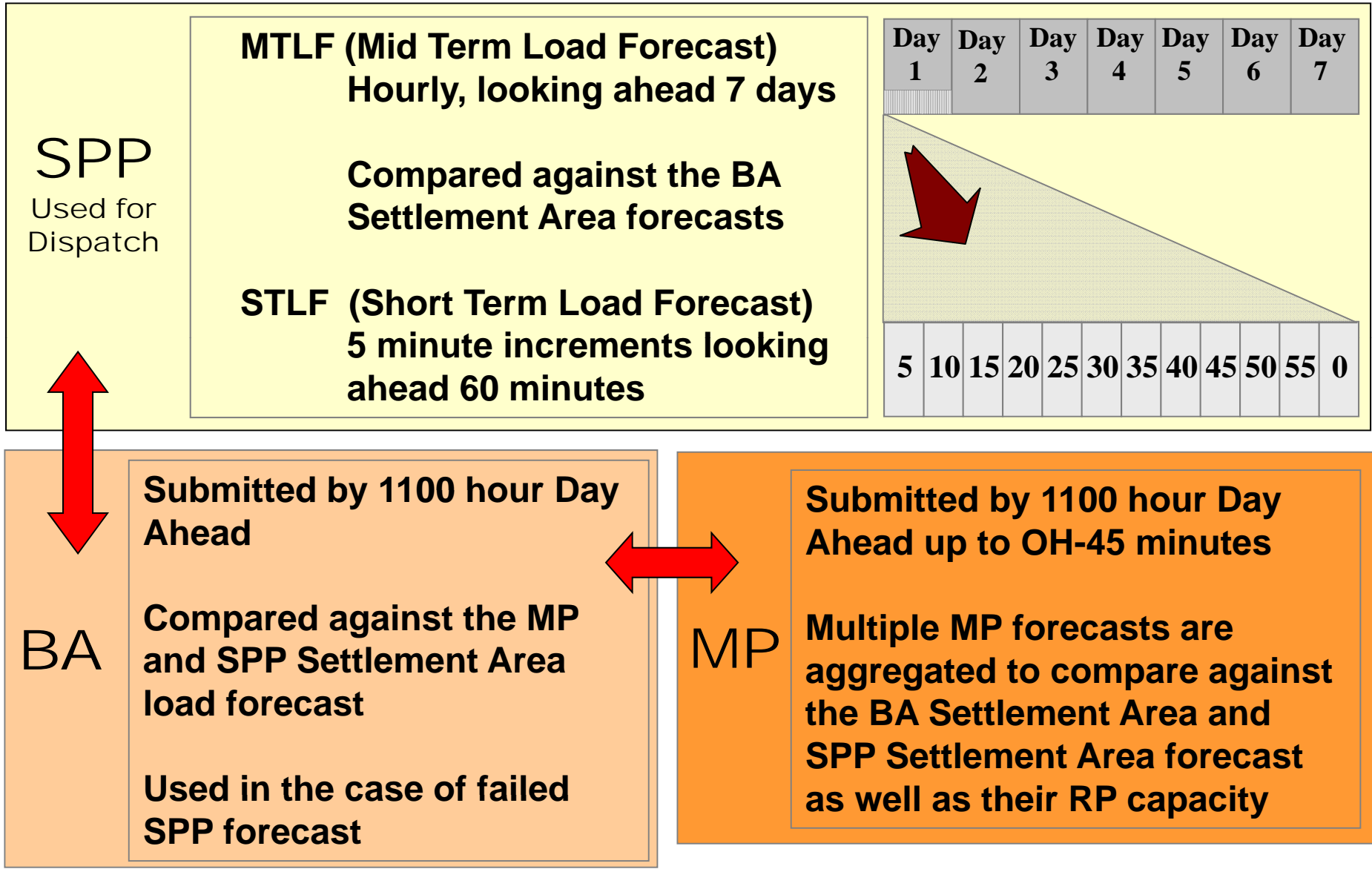



Quick Quiz Question



Does SPP calculate its own load forecast for the system and each BA, or does it rely solely upon those forecasts submitted by each BA?



Markets 301

Resource Plans

Resource Plans

- **All MPs with resources will be required to submit resource plans AND are required to keep the plan up to date throughout the operating day.**
- **Reliability criteria require that the resource plan cover a period of seven days, beginning with the operating day (168 hours).**
- **The resource plan contains entries for each resource for each hour of the seven day horizon, including:**
 - **Market Date**
 - **Resource Name**
 - **Hour Ending**
 - **Status**
 - **Planned MW**
 - **Minimum and Maximum Ratings (6)**
 - **Break Point(s) and Ramp Rates(s) → MW per Min**



Contents
of a RP



Resource Plans

- **How is a RP used?**
 - **For the Market**
 1. Used to determine dispatch instruction (when included with Offer curves, Load Forecast, and State Estimator).
 - **For Reliability**
 1. Use for SFT studies and Contingency Analysis
 2. Determine available transmission service
 3. Deliverability Analysis
- 1. **MO Manual Overrides**
 1. Used to update current hour RP in event MP is unable to for a current-hour physical change to the resource (contingency, de-rate, etc)
 2. OH-45 closes the MP changes to a RP



Resource Plans

- **Resource Status**

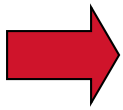

- **Manual**

1. **Not capable of following dispatch instruction by virtue of:**
 - A. **Testing**
 - B. **Intermittent resources**
 - C. **Start up or shut down mode**
2. **Zero ramp rate (dispatched to last observed output)**

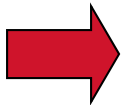

- **Available**

1. **Online and available for SPP Market Deployment**



Resource Plans

- **Resource Status**

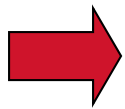

- **Self-dispatched**

1. Online, but unavailable for SPP Market Deployment.
2. SPP will send self-dispatched resources a dispatch signal that matches the sum of their schedules

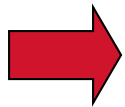

- **Unavailable**

1. Offline and unavailable for SPP Deployment
2. SPP Dispatch will take an online resource to zero output via Resource Plan ramp rate

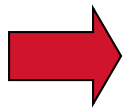

- **Supplemental**

1. Offline but capable of satisfying Supplemental reserve requirements. Will not be dispatched by the MOS

Resource Plans

- **Capacity and Ramp Rate data submitted**
 - **Emergency Minimum Capacity Operating Limit**
 - **Min Limit**
 - **Economic Minimum Capacity Operating Limit**
 - **Economic Maximum Capacity Operating Limit**
 - **Max Limit**
 - **Emergency Maximum Capacity Operating Limit**

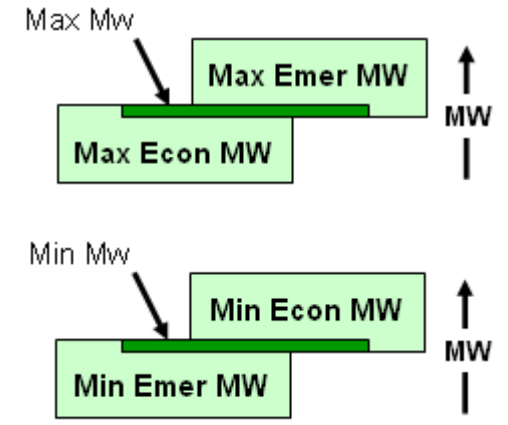

- **Ramp Rate profiles (segment) for:**

1. Up ramp rate limit
2. Down ramp rate limit
3. Emergency ramp rate limit
4. Ramp rate break point(s)

3

For

1

MOS only utilizes Economic limits for dispatch instruction (Max, Min, and Ramp)



Portal & XML Changes

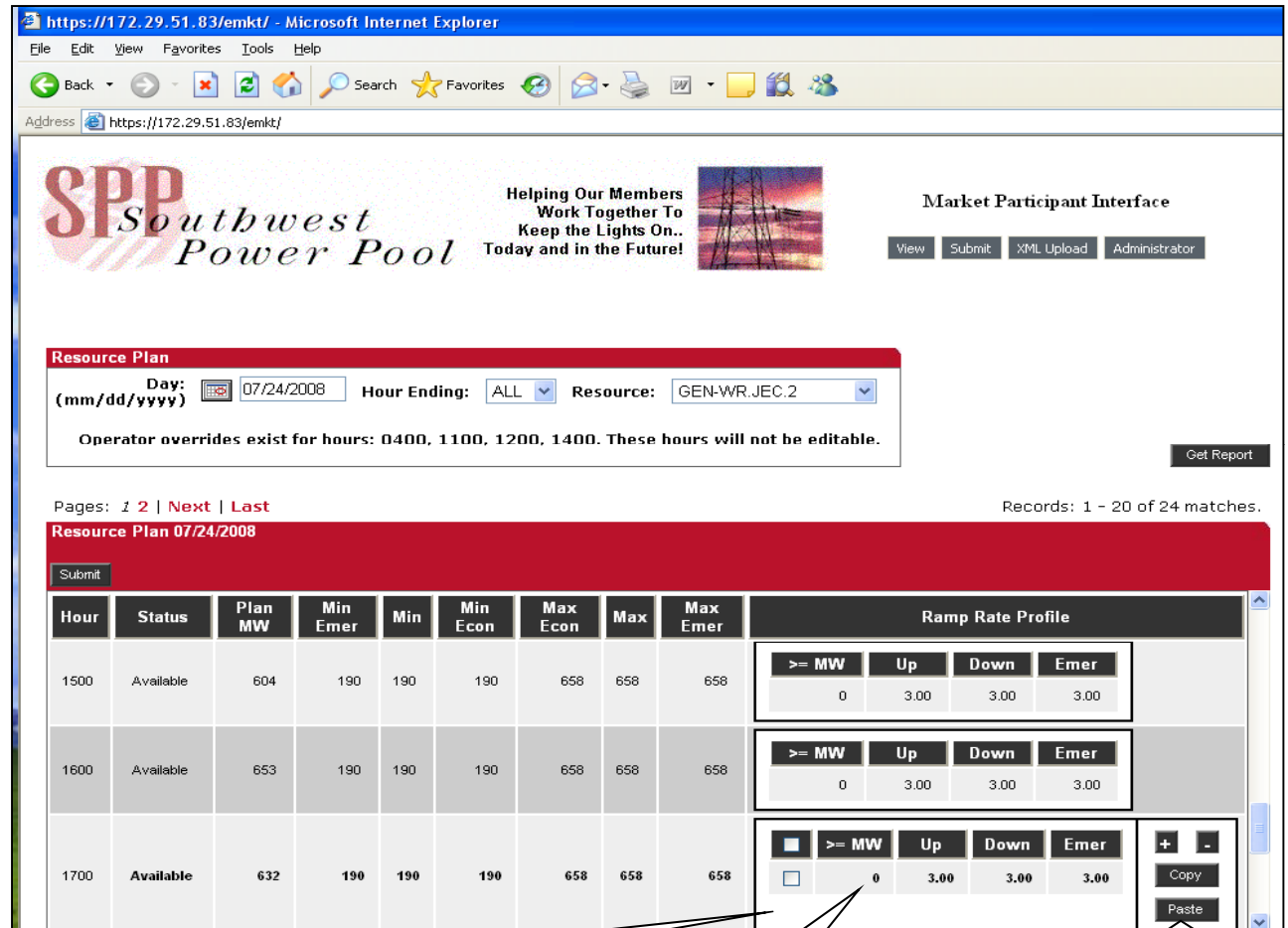

The screenshot shows the SPP Market Participant Interface. At the top, there is a navigation bar with buttons for View, Submit, XML Upload, and Administrator. Below this is a 'Resource Plan' section with a form for Day (07/24/2008), Hour Ending (ALL), and Resource (GEN-WR.JEC.2). A 'Get Report' button is located to the right. Below the form, there are navigation links for pages 1, 2, Next, and Last, and a record count of 1 - 20 of 24 matches. The main content is a table titled 'Resource Plan 07/24/2008' with a 'Submit' button above it. The table has columns for Hour, Status, Plan MW, Min Emer, Min, Min Econ, Max Econ, Max, Max Emer, and Ramp Rate Profile. The Ramp Rate Profile column contains sub-tables for each hour, with columns for >= MW, Up, Down, and Emer. The 1700 hour row is highlighted, and a callout box points to a small square icon in the first column of its Ramp Rate Profile sub-table.

Hour	Status	Plan MW	Min Emer	Min	Min Econ	Max Econ	Max	Max Emer	Ramp Rate Profile										
1500	Available	604	190	190	190	658	658	658	<table border="1"> <thead> <tr> <th>>= MW</th> <th>Up</th> <th>Down</th> <th>Emer</th> </tr> </thead> <tbody> <tr> <td>0</td> <td>3.00</td> <td>3.00</td> <td>3.00</td> </tr> </tbody> </table>	>= MW	Up	Down	Emer	0	3.00	3.00	3.00		
>= MW	Up	Down	Emer																
0	3.00	3.00	3.00																
1600	Available	653	190	190	190	658	658	658	<table border="1"> <thead> <tr> <th>>= MW</th> <th>Up</th> <th>Down</th> <th>Emer</th> </tr> </thead> <tbody> <tr> <td>0</td> <td>3.00</td> <td>3.00</td> <td>3.00</td> </tr> </tbody> </table>	>= MW	Up	Down	Emer	0	3.00	3.00	3.00		
>= MW	Up	Down	Emer																
0	3.00	3.00	3.00																
1700	Available	632	190	190	190	658	658	658	<table border="1"> <thead> <tr> <th><input type="checkbox"/> >= MW</th> <th>Up</th> <th>Down</th> <th>Emer</th> <th>+ -</th> </tr> </thead> <tbody> <tr> <td><input type="checkbox"/> 0</td> <td>3.00</td> <td>3.00</td> <td>3.00</td> <td>Copy Paste</td> </tr> </tbody> </table>	<input type="checkbox"/> >= MW	Up	Down	Emer	+ -	<input type="checkbox"/> 0	3.00	3.00	3.00	Copy Paste
<input type="checkbox"/> >= MW	Up	Down	Emer	+ -															
<input type="checkbox"/> 0	3.00	3.00	3.00	Copy Paste															

Ramp Rate Profile allows separate Econ UP and DOWN ramp rates as well as Emer ramp rates. Clicking on the left box will “tag” the row for further action (remove, copy, or paste).

Identifies a Break Point

Clicking on the + box will add additional rows (segments) of ramp rates. Clicking on the – box will remove the tagged row.



Quick Quiz Question



What data is the primary factor in calculating the dispatch value of a Self-Scheduled resource?

A resource plan indicates a specific resource will respond to RSS events, but is off line. What status would this resource carry?



Markets 301

Ancillary Service (A/S) Capacity Plans



Introduction to Ancillary Service (A/S) Capacity Plans

- **The Ancillary Capacity Plan (also referred to as the A/S Plan) is submitted by each MP to enable the SPP Market Operations System (MOS) the ability to confirm each MP is satisfying its ancillary service obligations.**
- **The A/S Capacity Plan notifies the SPP MOS which units will carry what amount of regulation and contingency reserves**
- **The A/S capacity plan indicates transfers of obligations between MPs and, when self-arranged, which resources are providing these services.**
- **A/S capacity plans will be used by MOS to ensure that EIS deployment does not consume unloaded capacity being utilized for other A/S.**



Ancillary Service Plans

- **Contents of the AS plan**
 - **Time period (Operating Day and Hour)**
 - **Counter Party**
 1. **Scheduled from / to**
 - **Counter Party type (MP, PLT, GEN, CLD, RTO)**
 - **A/S schedules (resource and obligation)**
 - **MW**
 - **BA**
 - **Regulation type (Up/Down)**
 - **Operating Reserve (spinning and supplemental)**



Ancillary Service Plans

- **External Generation**
 - **No Ancillary Service Plan will be submitted nor accepted by an External Resource**

A/S Capacity Plan (Portal)



ITE ENVIRONMENT

MOS Super User
PTC

2/17/2009 11:22:28 CST

CUSTOMER RELATIONS MARKET SETTLEMENTS MARKET OPERATIONS HELP

View

Submit

XML Upload

Admin

Summary box indicates the MP's A/S obligation. Notice no obligation exists for the URS and DRS, yet these values are important in determining the dispatchable range for each resource

The objective is a result of 0 (zero) imbalance MW. This indicates the MP has shown that A/S obligations have been accounted for and met by specific resources.

AS Capacity Plan

Day: Hour Ending: Service Type: Control Area:

AS Capacity Plan vs. AS Obligation Summary

Hour	Control Area	Serv. Type	Assigned Obl. MW	Plan Obl. MW	Plan Res. MW	Deficiency	Imbalance
0100	OPPD	DRS	0	0	0	0	0
0100	OPPD	SPIN	17	17	17	17	0
0100	OPPD	SUPP	16	16	16	16	0

Get Report

No data found.

AS Capacity Plan 2/17/2009

Add Delete Submit Cancel

Hour Ending	Type	Service Type	MW	Control Area	Resource/Counterparty
-------------	------	--------------	----	--------------	-----------------------



Quick Quiz Question



Is a resource's Max and Min capacity included in its Resource Plan, or in its Ancillary Service Plan?



Markets 301

Offer Submission & Offer Curves



Offer Curves

- **Used by MOS in determining the most economical dispatch of Market resources - SCED (Security Constrained Economic Dispatch)**
 - **Used in the calculation of LIP (Locational Imbalance Pricing)**
 - **Used with “Available” resources**
 - **Price of resource is specified through an offer curve**



Offer Curves

- **Curve represented by 2 to 10 monotonically increasing prices. Price may be positive or negative**
- **Prices may be positive or negative**
- **Prices interpolated between offer curve price points**
- **Submitted by MP for next 7 days**
 - **MP cannot change the Offer Curve within OH-45 minutes**



Offer Curves

- **Contents**
 - **Date and Hour Ending**
 - **Resource**
 - **Price/MW**

Offer Curves

Example of an Offer curve for Market dispatch

<u>Submitted Data</u>	
(MW)	\$
0	\$0.00
100	\$20.00
200	\$25.00
400	\$25.01
500	\$50.00

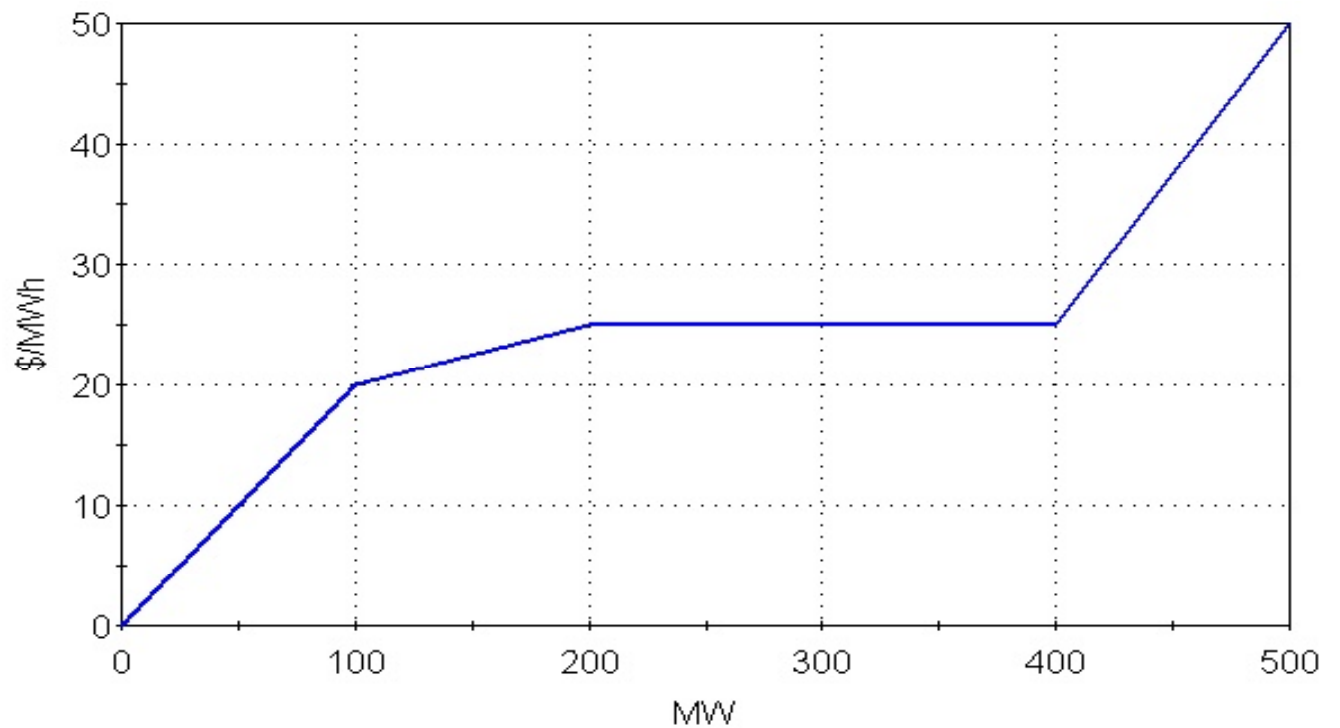

Offer Curve Submission

- If an offer curve does not have 0 MW as the first MW point, SPP will insert a point at the beginning of the offer curve at 0 MW and the price equal to the first MW price pair submitted by the MP.
- The last price point on the Offer Curve is used to price all MWs between that point and the Maximum Capacity from the Resource Plan.

MW	\$/MW
0	10
10	10
20	25
30	30
40	45
55	60
75	62
80	65
90	70
100	75
150	75

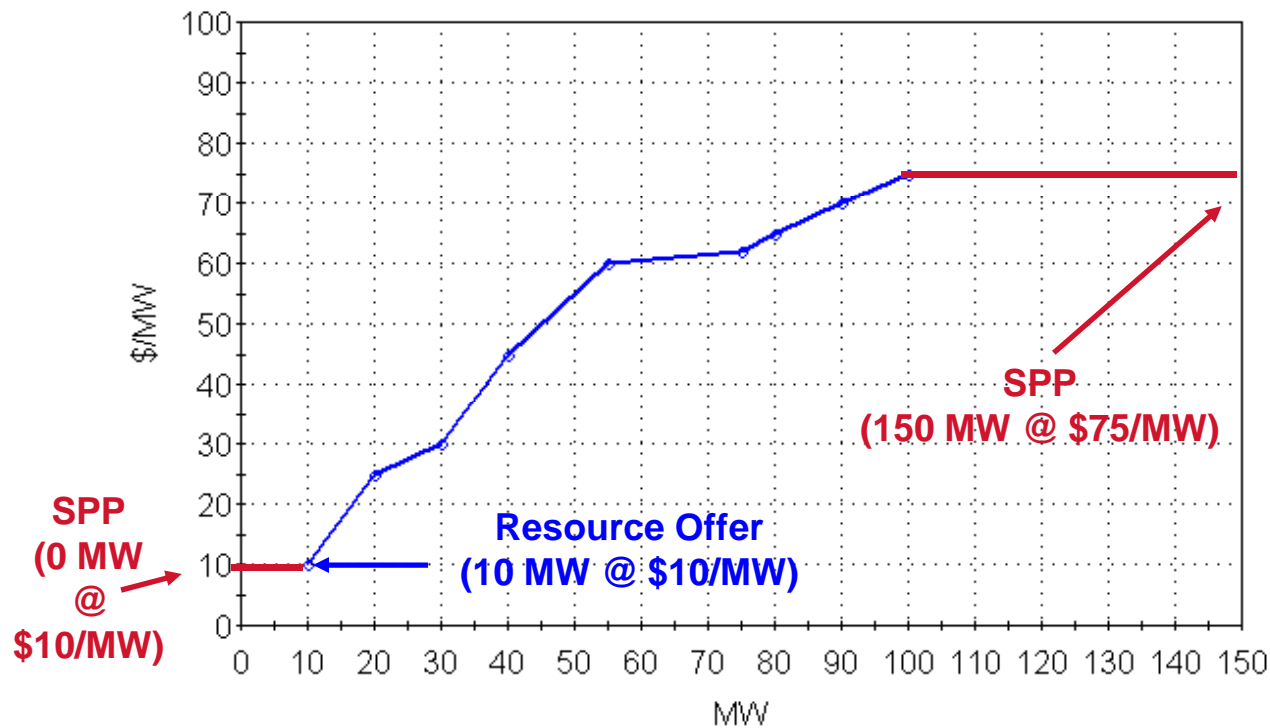

Offer Curve (Portal)

EIS Offers

Day: Hour Ending: Resource:

d.dd Indicates price exceeds offer cap

[Get Report](#)

EIS Offers 06/06/2006

[Delete](#) [Submit](#)

Hour Ending	Resource	Price Curve														
		MW	Price	Cap:	Cap Disabled											
<input checked="" type="checkbox"/>	0100	PLT-ABC	(null)	(null)	(null)	(null)	(null)	(null)	(null)	(null)	(null)	(null)	(null)	(null)	(null)	(null)
<input type="checkbox"/>	0200	PLT-ABC	(null)	(null)	(null)	(null)	(null)	(null)	(null)	(null)	(null)	(null)	(null)	(null)	(null)	(null)
			(null)	(null)	(null)	(null)	(null)	(null)	(null)	(null)	(null)	(null)	(null)	(null)	(null)	(null)



Quick Quiz Question



Can an Offer Curve be submitted with a price curve that decreases in price as MW increase?

What is the minimum number of Price/MW offer curve point that may be submitted?



Markets 301

Dispatchable Range



Dispatchable Range

- Dispatchable Range based upon data from:

- Offer curves
- RPs
- AS Plans
- State Estimator

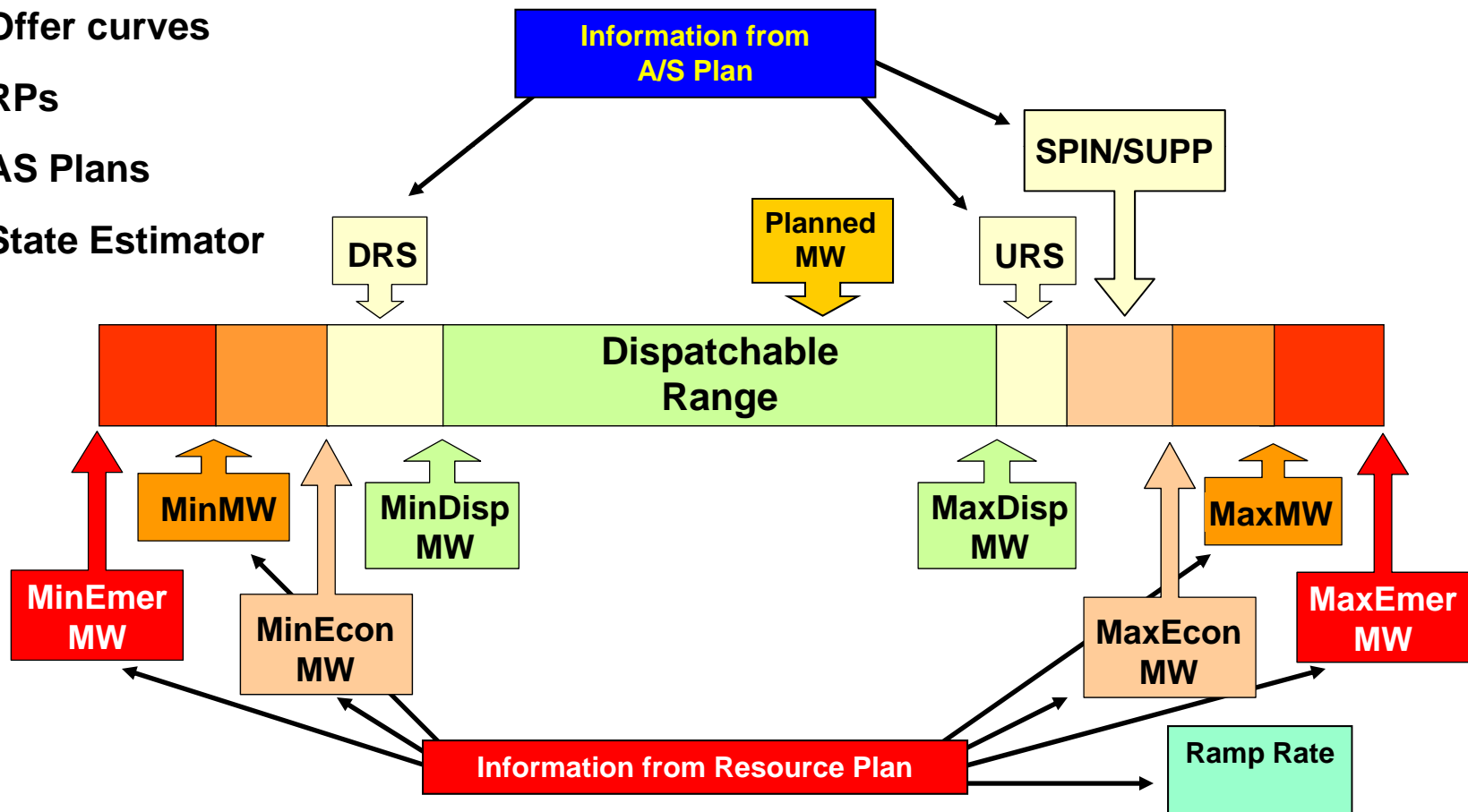

Dispatchable Range

Resource Plan

Market Date MM/DD/YYYY	Resource Name	Hour Ending	Status	Planned MW	Net Min Rating	Net Max Rating	Ramp Rate MW/Min
05/15/2006	GEN- JonesCo	11	Available	300	170	350	4.0

Ancillary Service Plan

Date MM/DD/YYYY	Hour Ending	A/S Service Type	Control Area Name	Type	MW	Resource/ Counterparty
05/15/2006	11	SPIN	CSWS	OBL	10	RTO
05/15/2006	11	SPIN	CSWS	RES	10	GEN-JonesCo
05/15/2006	11	SUPP	CSWS	OBL	10	RTO
05/15/2006	11	SUPP	CSWS	RES	10	GEN-JonesCo
05/15/2006	11	URS	CSWS	OBL	5	RTO
05/15/2006	11	URS	CSWS	RES	5	GEN-JonesCo
05/15/2006	11	DRS	CSWS	OBL	5	RTO
05/15/2006	11	DRS	CSWS	RES	5	GEN-JonesCo

Dispatchable Range

Submitted Data

(MW)	\$
0	\$0.00
50	\$20.00
100	\$30.00
200	\$35.00
300	\$50.00
350	\$60.00

Offer Curve for JonesCo

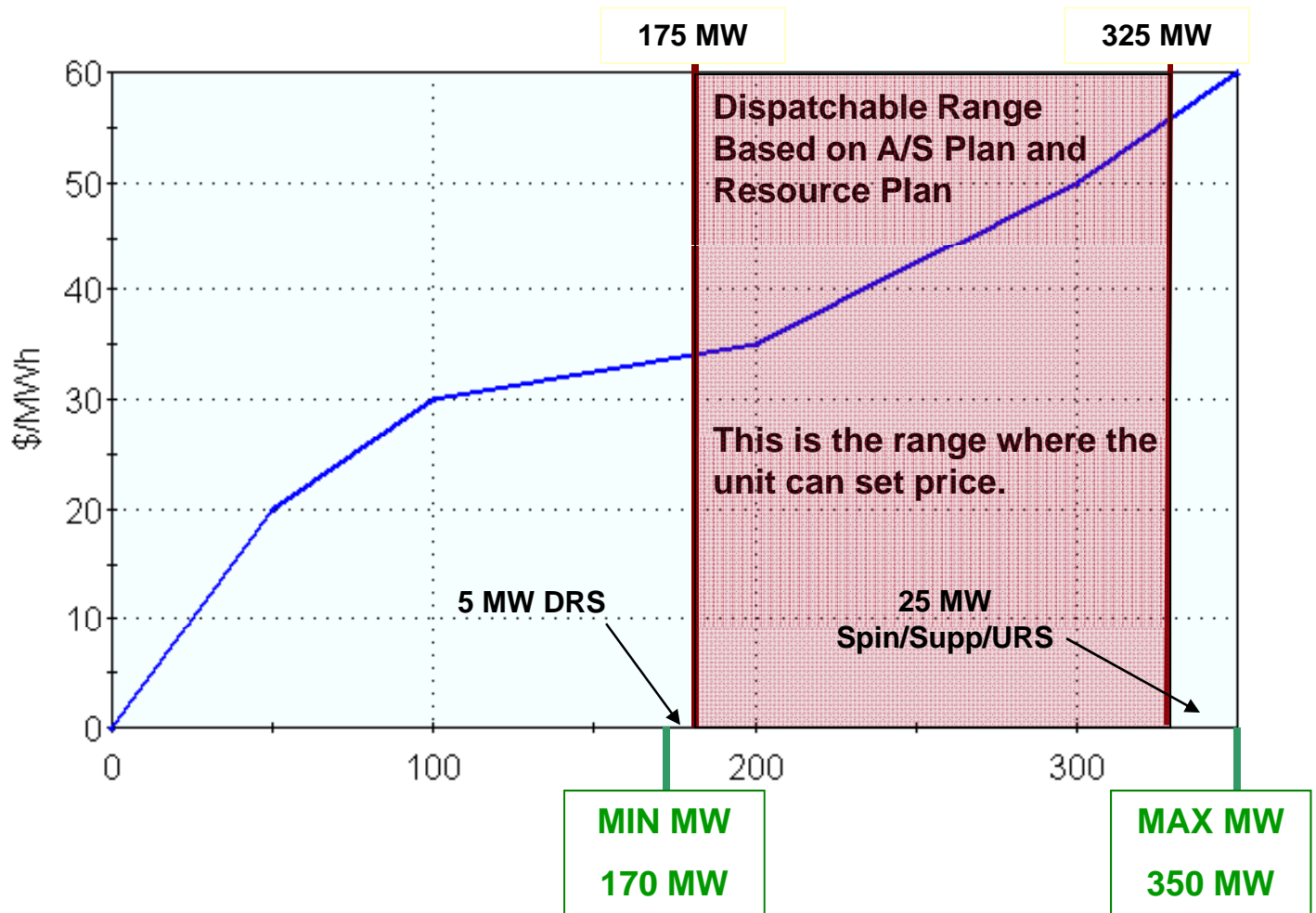

Quick Quiz Question 

Based on the RP, what would be the upper limit of the Dispatchable Range if no Spin or Supp were placed on this resource?



Markets 301

Deployment



Introduction to Deployment

- **SPP shall determine the least costly means of obtaining energy to serve the next increment (MW) of load at each settlement location, while maintaining reliability.**
 - **This is SCED (Security Constrained Economic Dispatch)**
- **In performing these calculations, SPP will use the EIS offers that can serve the load at a bus at the lowest cost.**
- **This deployment determines the dispatch instructions for resources that have offered to provide EIS (Available status).**





Introduction to Deployments

- **The mathematical computation (a.k.a. SCED) produces two primary outputs:**
 - **Deployment instructions**
 1. **Deployment instructions are generated for EVERY resource regardless of whether it's offered to SPP**
 - **Prices for every node in the system**
 1. **Every load bus and every generator bus gets a price**
 2. **Load bus prices “roll up” into larger load prices used in settlements**



Introduction to Deployments

- **Deployments are the result of a mathematical computation that utilizes certain inputs:**
 - **Actual SCADA for each resource (10 minutes prior to the end of the interval being calculated)**
 - **State estimator information for resources with bad SCADA**
 - **A load forecast for the market footprint (for the end of the interval being calculated)**
 - **Market data**
 1. **Resource plans**
 2. **Offer curves**
 3. **Ancillary service capacity plans**



Introduction to Deployment

- **Resources that have elected to be dispatched by SPP will have their entire MW capability under SPP dispatch control.**
- **Deployment values sent to all MP resources regardless of status.**



Determining Dispatch

- **SCED must predict what generation outside of its control will do in the next 10 minutes:**
 - “Unavailable” resources will move toward (or stay at) zero.
 - “Self scheduled” resources will move toward (or run at) scheduled levels
 - “Supplemental” and “Manual” resources will not move
- **SCED must predict what load will do in the next 10 minutes**
 - Performed on a BA by BA basis and rolled up to a market total
 - Adjusted for imports and exports into the market
- **SCED then uses “available” generation to make up the slack between resources (generators) and obligations (load)**



Deployment Information

- **Dispatch (Deployment) instructions include:**
 - Resource Name *
 - Market Date
 - Interval Ending (5 minute intervals)
 - Dispatch Type (EIS, OOME)
 - MW Set-Point *
 - Locational Imbalance Price (LIP) (\$/MWh)
 - Approval Time
- The dispatch instruction is a set-point for the **end of the deployment interval**, and is the value that the resource is expected to be at when that interval has ended

***ICCP Link information**



Deployment process

- **Dispatch instructions are calculated every 5 minutes.**
- **The process of calculating deployment begins 10 minutes prior to the end of that deployment interval.**
- **Ramp rate used in the dispatch instruction comes from the resource plan.**
- **The ramping is for the last 5 minutes of the 10 minute deployment interval.**
- **NSI is calculated every four seconds and includes the ramped impact of the deployment instructions.**



Deployment process

- **The dispatch instructions are communicated (via XML) approximately 5 minutes prior to the end of the deployment interval, which is 5 minutes prior to the time the MP is expected to begin moving the resource.**
- **Instructions are sent via ICCP exactly 5 minutes prior to the end of the interval (at the beginning of ramp time)**
- **Dispatch instruction for a self-dispatched unit is equal to the sum of its schedules for the end of the interval.**
- **At the end of each deployment interval, SPP takes a snapshot of each resource to determine if its output matches the instructed level.**

The Operating Hour

Each operating hour contains twelve 5-minute deployment intervals.

During each of these deployment intervals:

- MPs are ramping to achieve deployment, and
 - SPP is calculating NSI every four seconds and sending modified NSI to control areas via ICCP
-
- While the operating hour events are occurring in real-time, the MP and SPP are preparing in the hour ahead for the next operating hour.
 - So there is overlap of the hour-ahead and operating hour events.

A deployment interval is 5 minutes, and each OH has 12 deployment intervals (DI).

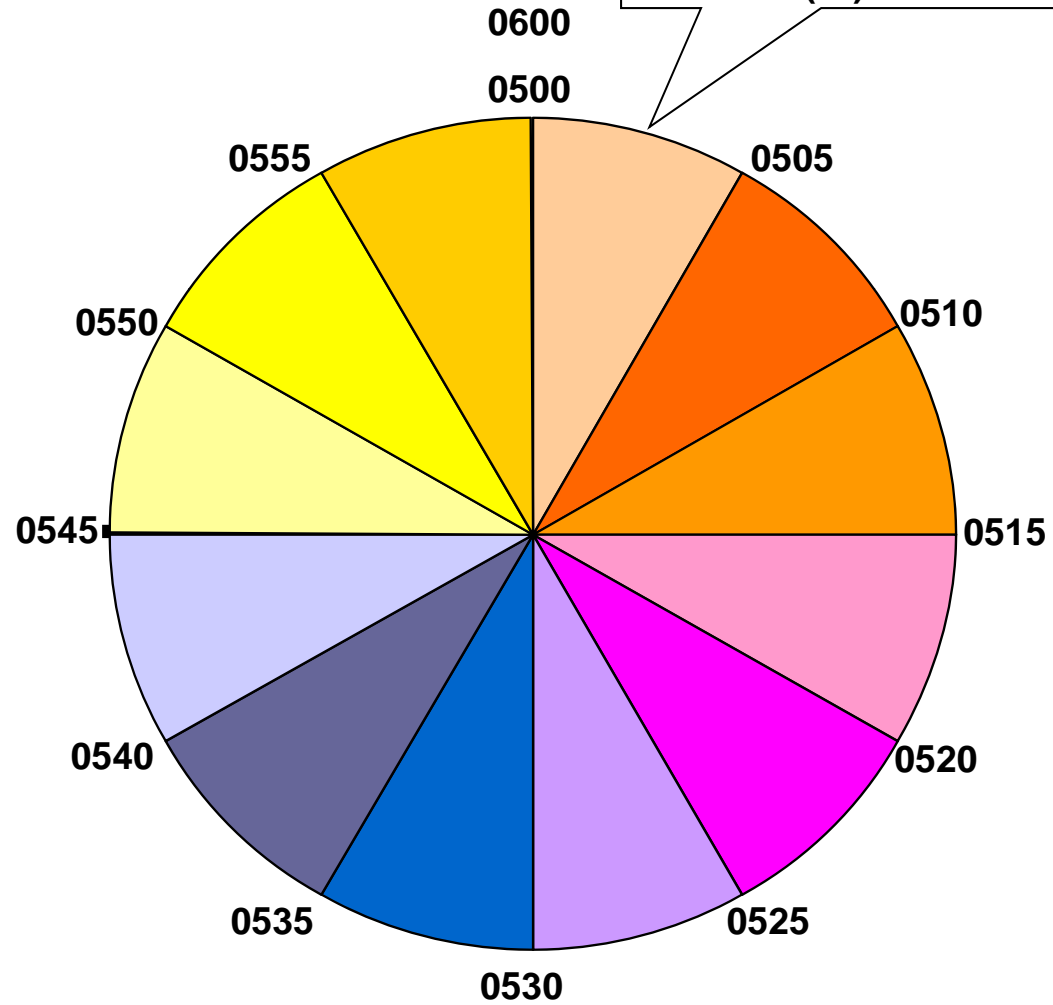

Ten-Minute Deployment Interval

Dispatch Instruction Timing

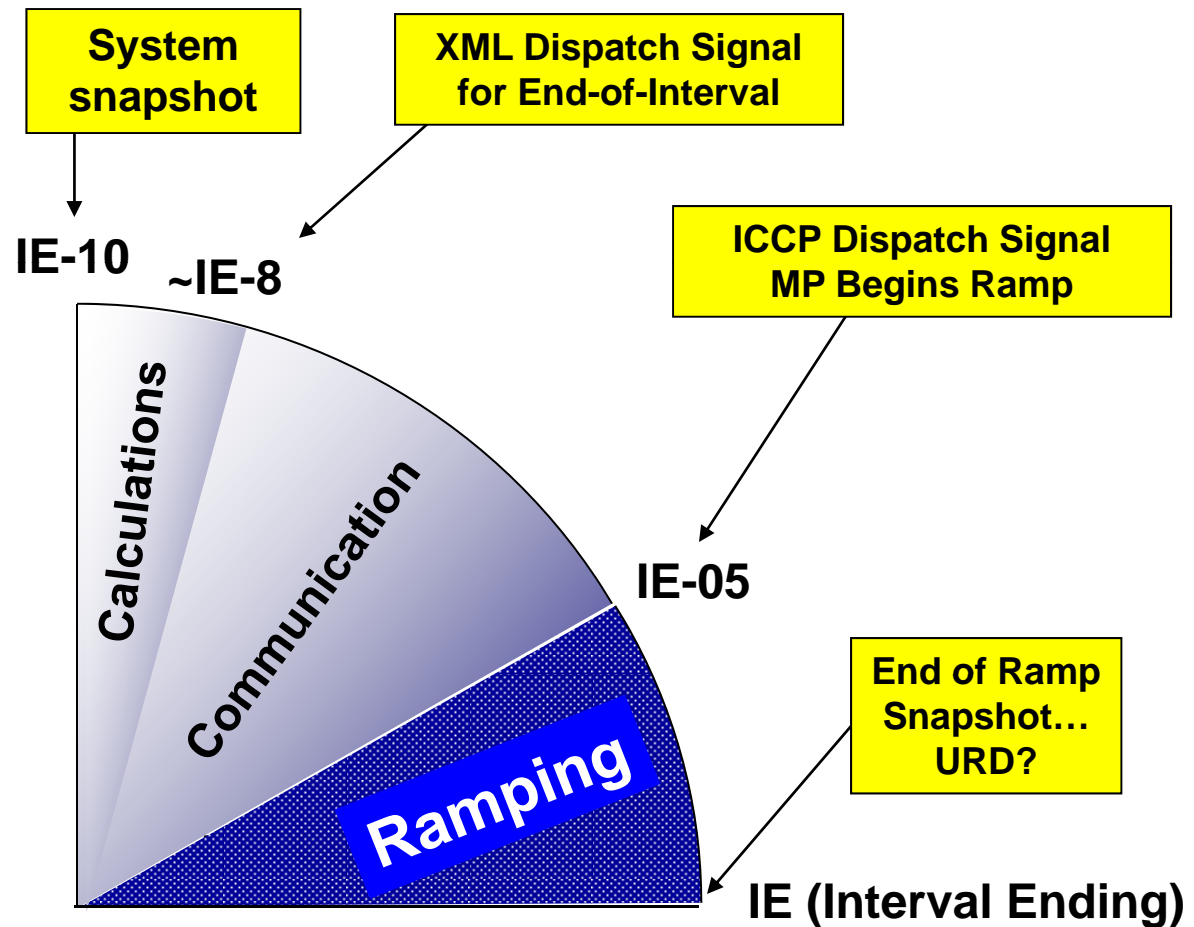

Deployment Process

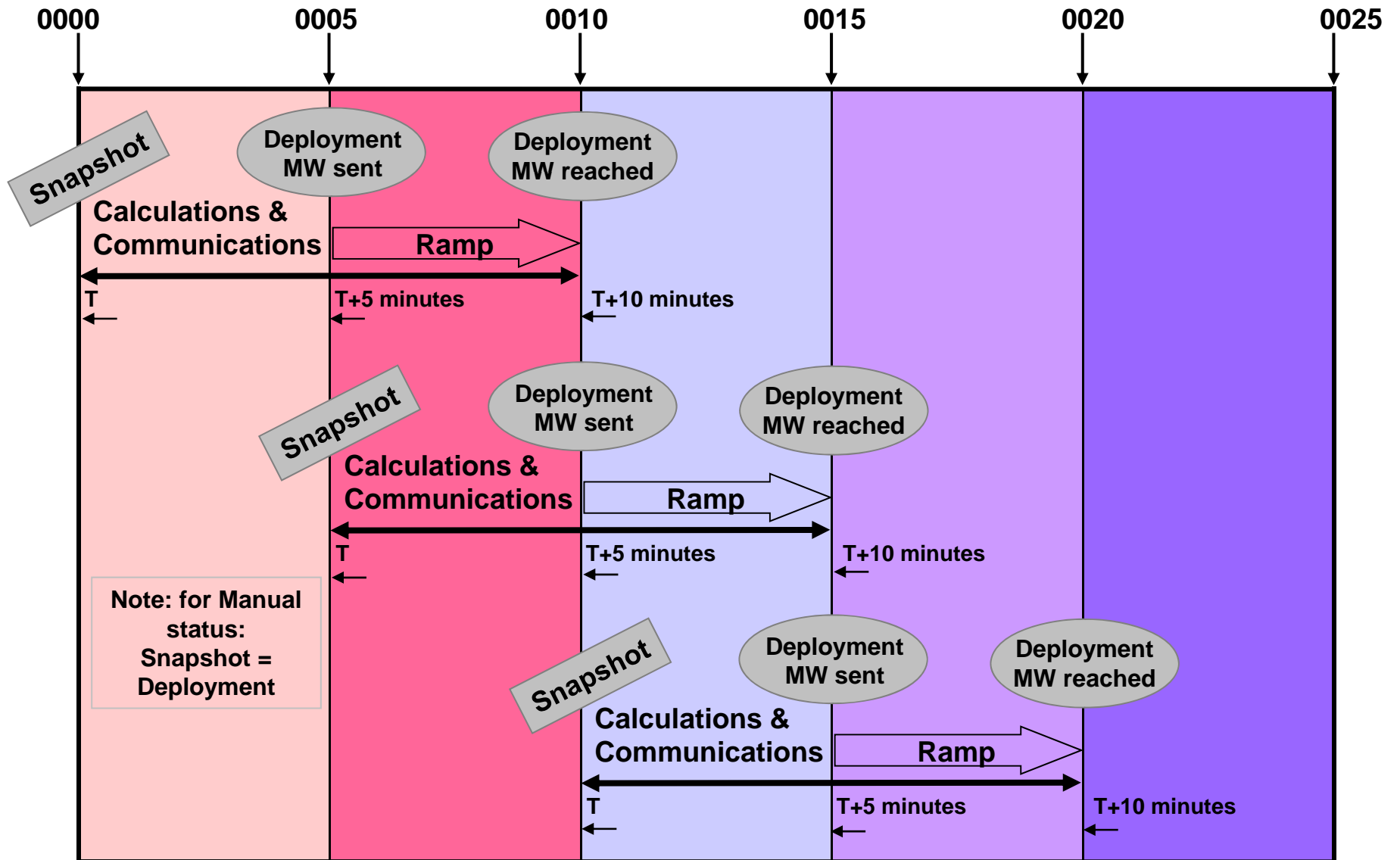

Deployment

Example of deployment for a resource that has a schedule and is offered into the Market

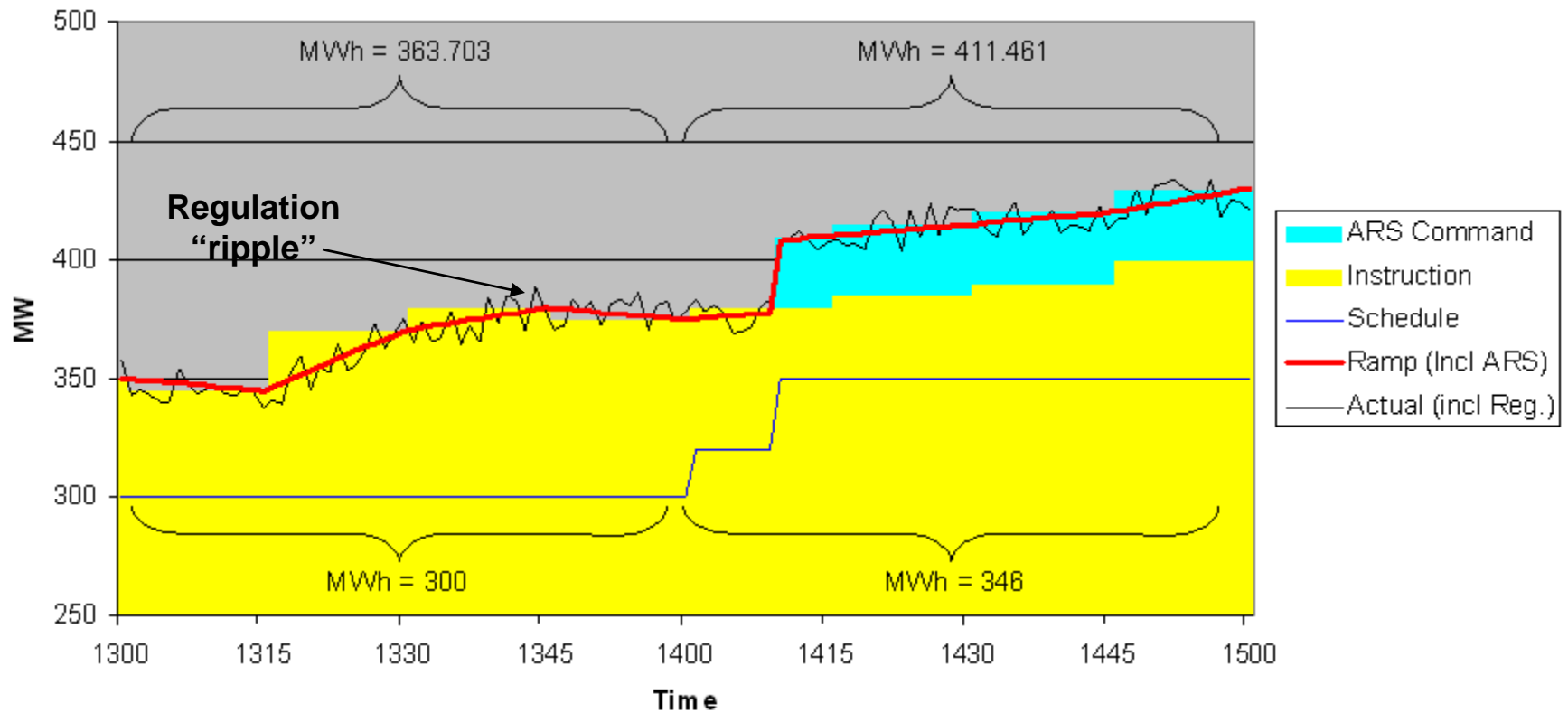



Deployment and Reserve Sharing System (RSS) Schedules

- **The Market Operating System (MOS) will automatically recognize a unit contingency and maintain the pre-contingency deployment until any RSS schedules come in.**
- **A qualifying unit contingency is identified as having:**
 - **greater than 50 MW max – as defined in Resource Plan - and one or both of the following:**
 - **value change of greater than 50% from previous interval**
 - **breaker status change to “Open”**
- **The pre-contingency deployment will be maintained for 3 intervals or until the RSS schedules come in – whichever comes first.**
- **SPP Market Operations has the ability to manually override (“turn off”) implementation of this logic at any time if needed for a given unit or situation. For example, combined cycle reconfiguration.**



Quick Quiz Question



Any Market response to a real-time event will be delayed by how many minutes?

How would you describe or define Security Constrained Economic Dispatch?



Markets 301

Market Timeline



Timeline

- **Broken down into 4 time segments**
 - **Day-Ahead Activities**
 - **Operating Day Activities**
 - **Operating Hour Activities**
 - **Post-Operating Day Activities**



Information Exchange Timeline

Day-Ahead Activities

MP Action



SPP Action

0730 (OD-1)		<ul style="list-style-type: none"> •Send AS obligations to each MP •Post 7 day hourly load forecast
1100 (OD-1)	MP submits RP (Resource Plan), Load Forecast, Offer Curve, and AS (Ancillary Service) plan	
1200 (OD-1)		Review the AS plans and notify BA/MP of imbalance or mismatch
1300 (OD-1)	MP updates plans to address mismatch and/or revise RP as needed	
1400 (OD-1)		Again, Review the AS plans and notify BA/MP of imbalance or mismatch
1300-1530 (OD-1)		Perform CA (Contingency Analysis) and notify parties of infeasibility

Operating Day EIS Activities Timeline

MP Action



SPP Action

<p>OD-7 to OD OH-45 min.</p>	<p>Submit offer curves (used for deployment) for upcoming hours and days</p>	<p>At OH-45min → Lock RP</p> 
<p>OH-30 min.</p>	<p>MP submits tags 30 minutes prior.</p>	<p>Tags</p> 
<p>OH-20 min.</p>	<p>Energy schedules must be approved OH-20 min prior</p>	 <p>Energy / NLS Schedules</p>
<p>Post-RSS</p>		<p>Create and submit schedules for RSS event (3 schedules) into RTO_SS</p>

Operating Hour Activities Timeline

MP Action

SPP Action

IE-10 min.		<ol style="list-style-type: none"> 1. System snapshot 2. Project Load (STLR) 3. Accept SE solution 4. Process OH schedules 5. Calculate SCED 
IE-10 min. to IE-05 min.		Send XML dispatch instruction
IE-5 min.	MP begins ramp to achieve IE dispatch instruction	Send ICCP dispatch instruction
IE	MP resource at instructed output	Records actual resource output 
OH+15 min.		SPP sends LIP for previous hour on Portal and at SPP.org
Every 4 sec.		Sends NSI value



Post Operating Day Activities Timeline

MP Action

SPP Action

0100 OD + 3 days	Offset load schedules to reflect actual resources used in an RSS event	
0100 OD+ 3 days	Estimated dynamic schedules may be updated	Perform checkout (including dynamic schedules)
OD+ 4 days	Submit actual Load, Resource, and Meter Data by noon	Final settlement statements by Location, Hour, and MP
OD+ 7 days		Initial settlement statements by Location, Hour, and MP
OD+ 45 days		Final settlement statements by Location, Hour, and MP



Quick Quiz Question



A MP's resource experiences a forced outage at H+20. How does the Market Participant change his resource plan or A/S plan to reflect this outage for the remainder of the hour?



Markets 301

Uninstructed Resource Deviation (URD)



Deployment

Uninstructed Deviation and Imbalance

- **Uninstructed deviation** is the difference between dispatch instructions and the actual performance of the resource **measured at a point in time.**

Actual - Dispatch (absolute)

- **Imbalance** is the difference between actual production or usage and scheduled production or usage for each asset **measured over a period of time.**

Actual - Scheduled



Uninstructed Deviation and Imbalance

Comparing URD to Energy Imbalance

Time	Schedule	Dispatch Instruction	Instantaneous Measurement	Uninstructed Deviation	Energy Imbalance
1205	100 MW	125 MW	135 MW	10 MW	-35 MW
1210	100 MW	125 MW	130 MW	5 MW	-30 MW
1215	100 MW	125 MW	125 MW	0 MW	-25 MW
1220	100 MW	125 MW	120 MW	5 MW	-20 MW
1225	100 MW	125 MW	115 MW	10 MW	-15 MW
1230	100 MW	125 MW	110 MW	15 MW	-10 MW
1235	100 MW	125 MW	105 MW	20 MW	-5 MW
1240	100 MW	125 MW	100 MW	25 MW	0 MW
1245	100 MW	125 MW	95 MW	30 MW	5 MW
1250	100 MW	125 MW	90 MW	35 MW	10 MW
1255	100 MW	125 MW	85 MW	40 MW	15 MW
1300	100 MW	125 MW	80 MW	45 MW	20 MW

Imbalance = Actual MW – Scheduled MW

URD = Actual MW – Dispatch instruction MW

Absolute Value



Uninstructed Resource Deviation (URD)

- **Market participants that deviate from SPP dispatch instructions will incur financial penalties (Uninstructed Resource Deviation Charge, or URD).**
 - **Available** resources are dispatched economically based on the Offer Curves submitted and will be subject to URD charges for deviations outside the allowable bandwidth.
 - **Self-Dispatched Resources** are sent a dispatch instruction based on the sum of their schedules and will be subject to URD charges
 - A “**Manual**” status will be exempt from Uninstructed Deviation charges (unit testing, coming on or off line, etc).
 - All deviation values are **absolute values** with no netting



Uninstructed Resource Deviation (URD)

- **The bandwidth is determined as 10% of the Max MW per unit (from the Resource Plan), limited to a minimum of 5 MW and a maximum of 25 MW, and further adjusted for any up or down regulation capacity being held.**
- **Intermittent resources** are not subject to URD.
- **Resource Operating Tolerance**
 - **+/- 10% of Max MW in the Resource Plan per unit**
 1. **But no less than a 5 MW tolerance**
 2. **And no more than a 25 MW tolerance**
 - **Plus the regulation set aside for the resource**
 1. **URS (Up Regulation Service)**
 2. **DRS (Down Regulation Service)**
 - **As indicated at the End of the Dispatch Interval**

URD and Resource Operating Tolerance

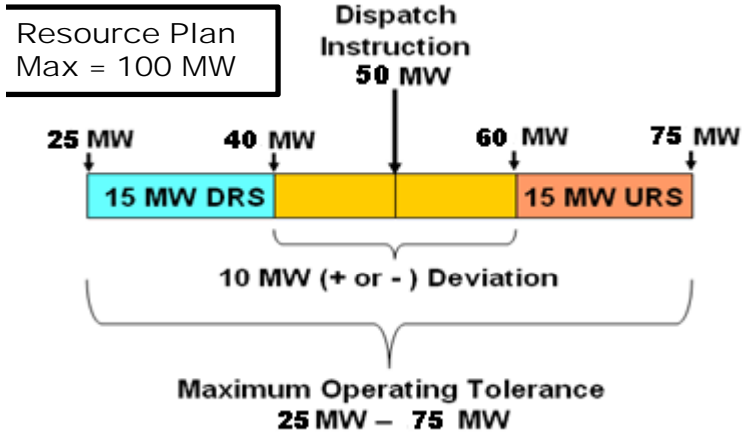

Example 1: URD showing full use of the 10 (+ or -) and this resource's regulation

The normal 50 MW allowance (10%) is capped at the 25 MW maximum deviation limit

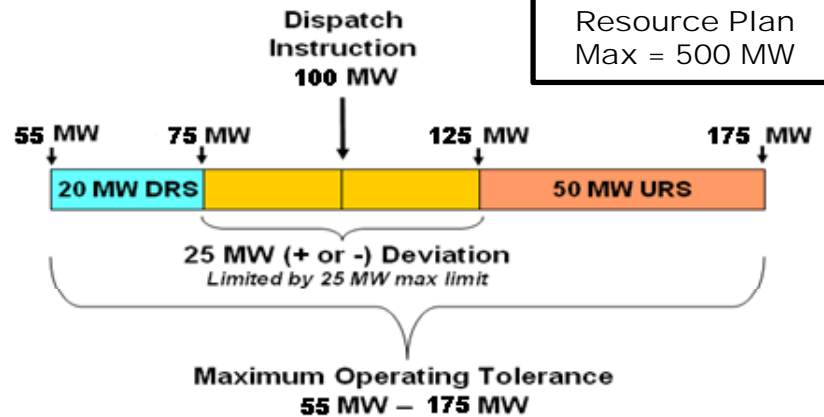

Example 2: URD showing that the 10% window is larger than the 25 MW maximum deviation limit

The normal 3 MW allowance (10%) is below the 5 MW minimum deviation limit

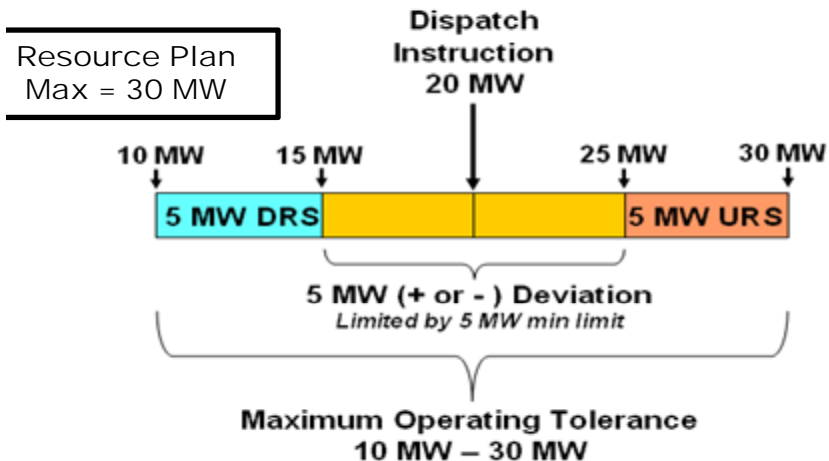

Example 3: URD showing that the 10% window is smaller than the 5 MW minimum deviation limit



Uninstructed Resource Deviation (URD)

- **Waiving URD**

- ***During RSS (Reserve Sharing System) Events**

1. Only for resources carrying Spinning and Supplemental energy

- **Intermittent Resources**

1. Wind
2. Run-of-the-river

Flagged as intermittent,
and uses “Manual” status

A light blue rectangular callout box with a black border and a white arrow pointing left towards the 'Intermittent Resources' section.

- **Conditions beyond the control, and without fault or negligence of the MP**
- **Manual status**
- ***Negative SCADA (aux load / pumping)**
- ***Ramp Rate Violations not caused by A/S plan being unattainable**
- ***OOME Dispatch**

***Automatic Waiver**



Quick Quiz Question



What is the URD bandwidth of a 60 MW resource, Market dispatched to 40 MW?

A resource is scheduled to generate 200 MW, the SPP Market dispatch for this resource is 300 MW, and the resource's actual output is 270 MW (no AS carried on this resource). What is the maximum allowable deviation (in MW) for this resource without incurring URD?

Self-Dispatch and URD

Example:

- If a self-dispatch resource is running at 310 MW with an unchanged Schedule target of 200 MW, this resource may be outside the URD bandwidth
- SPP will set the self-dispatch resource in the dispatch engine at shadow dispatch of 250 MW ($310 - 60 = 250$) due to ramp rate limits, but will continue to send a deployment instruction of 200 MW.
- URD is calculated based on a dispatch of 200 MW.

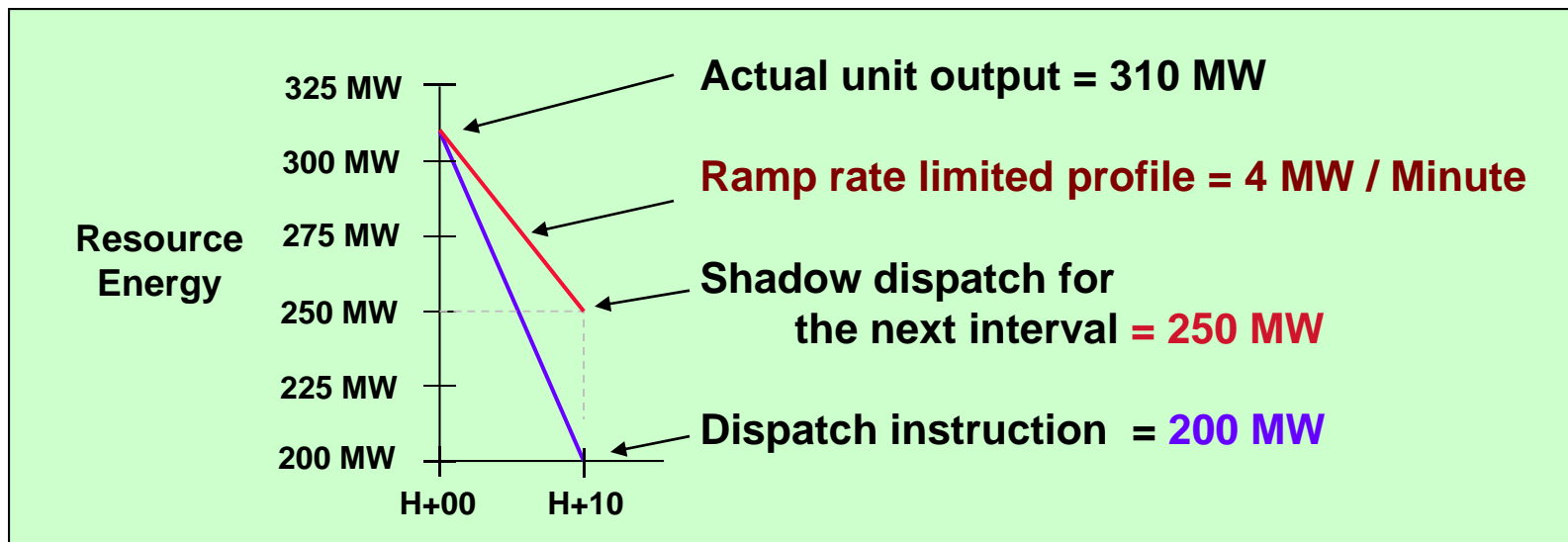



Markets 301

Energy Schedules



Energy Schedules

- **Energy Schedules**
 - **Used in the SPP contingency analysis, determining generation needs, and calculating NSI**
 - **Submitted by MP to reflect Market, Bilateral and Self-dispatch activities**
 - **No later than OH-30 minutes for tag submission**
 - **No later than OH-20 for NLS schedules**



Energy Schedules

- **Not required to match load**
- **Schedules classified as one of two types**
 - **Physical (Self-dispatched and SPP interchange)**
 - **Curtailments via IDC**
 - **Financial (Available resources and sourced from Load Settlement Location)**
 - **Curtailments via CAT**



Energy Schedules

- **Physical Schedules**
 - **Self-dispatched (resource is not offered into the Market)**
 - **MOS will dispatch to the sum of the resource's schedules**
 - **Schedules submitted through the RTO-SS system**
 - **Shall not exceed resource "MaxMW" limit**
 - **Curtailment of this schedule directly affect flow on flowgate**



Energy Schedules - Self-Dispatched Resources

- **Dispatch value will be the sum of schedules includes all tagged (energy and dynamic) schedules, NLS schedules and Reserve Sharing Schedules that are contained in RTO_SS.**
- **These resources may only be dispatched outside of the sum of the schedules in a system emergency (a manual “out of merit energy” or “OOME” dispatch instruction sent by the Market Operator).**
- **If Self-Dispatched Resource, the schedule will be a [Physical Schedule](#) provided it is not an NLS.**



Energy Schedules

- **Financial Schedules**

- **Resource is scheduled, and the resource has been offered into the Market (Available resource)**
- **Schedules are submitted through the SPP RTO-SS or the NLS (Native Load Scheduling)**
- **Curtailement of this schedule may directly affect the financial aspect of the transaction rather than the actual flow on the flowgate.**
- **If the MP submits both a schedule and an offer, the dispatch system will ignore the scheduled output for each Resource and calculate a Dispatch Instruction for the Resource based on the Offer Price and the information in the Resource Plan.**

Financial vs Physical schedule impacts

Physical Schedule

Self-Scheduled Resource with a Non-Firm BA-to-BA schedule for 100 MW

Pre TLR	Scheduled = 100 MW Actual = 100 MW
Post TLR	Scheduled = 50 MW Actual = 50 MW

Financial Schedule

Available Resource with a Firm BA-to-BA schedule for 100 MW

Pre TLR	Scheduled = 100 MW Actual = 100 MW
Post TLR	Scheduled = 100 MW Actual = 50 MW

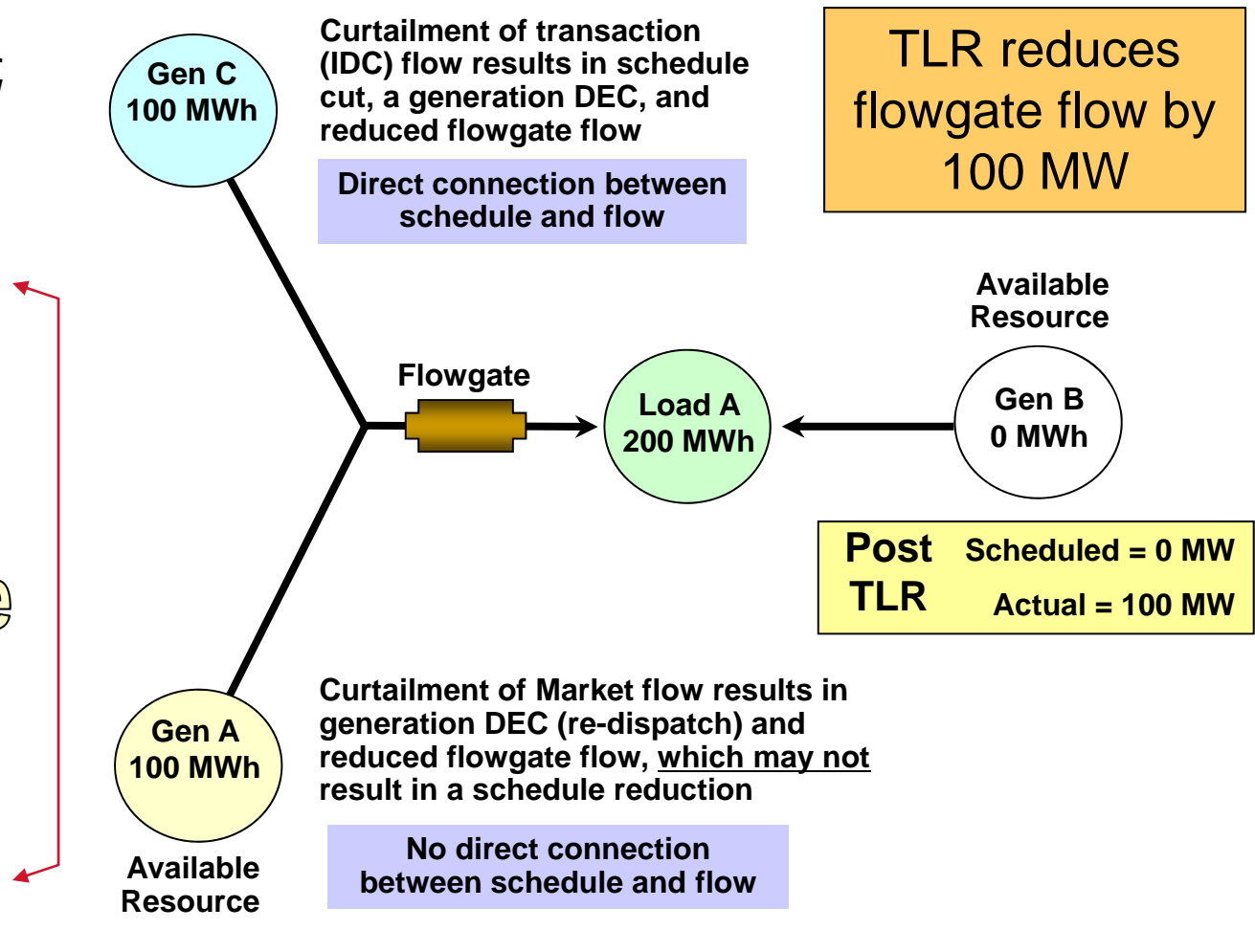

Financial vs Physical schedule impacts

- What is Schedule Infeasibility?**

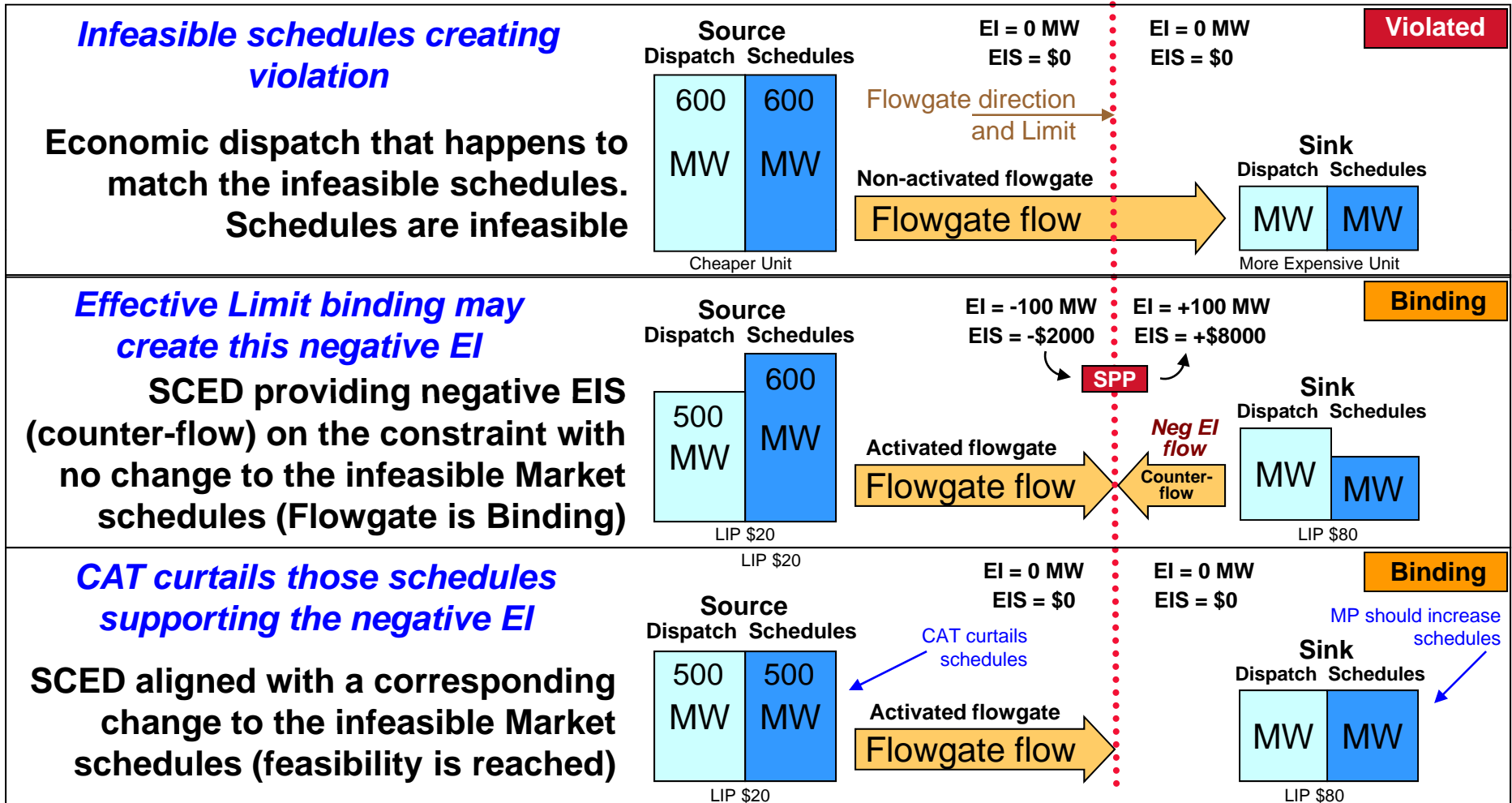



Energy Schedules

- **NLS (Native Load Schedules)**
 - **Only Intra-Control Area schedules between Settlement locations registered by same Transmission Owner**
 - **Does not utilize NERC tag**
 - **Cannot exceed Designated Resource Capacity list**
 - **Automatically accepted by SPP provided specific rules are met**



Energy Schedules

- **RSS (Reserve Sharing System) Schedules**
 - RSS deployments are “scheduled” and inserted into NSI
 - Treated as a bilateral Market schedules
 - Based upon resources identified as carrying Spin and Supp Reserves
 - Actual schedule can be submitted no later than 0100 three days after the RSS event OH

Energy Schedules

- RSS Scheduling**

Resource Schedule

This is an Intra-CA schedule used to identify the specific unit (source) used for the Assistance Schedule

Assistance Schedule

This is the CA-to-CA schedule for the assistance from the various participants

Outage Schedule

This is an Intra-CA schedule that schedules the imports to the specific unit (sink) that was lost

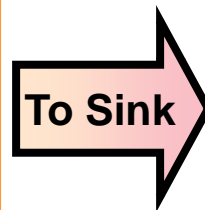
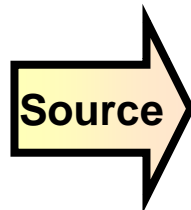

KCPLGENXYZ > KCPL 3mw
 KCPLGENUVW > KCPL 2mw
 EDEGENABC > EDE 3mw
 WRGENDEF > WR 10mw

- WR amount is ORF
- EES is not a Market Resource
- KCPL uses two units

KCPL > SWPP > WR 5mw
 EDE > SWPP > WR 3mw
 EES > SWPP > WR 25mw

This is the 33mw of assistance called for by RSS

WR > WRGENXYZ 43mw

Lost 43mw of which 10mw is covered by "Own Reserves First" (ORF)



Energy Schedules

- **External Generation**
 - **Scheduled amount cannot exceed Transmission Service Limit**
 - **Schedule will be curtailed by the NERC IDC process**
 - **Scheduled amount cannot exceed TLR curtailment allowed flow**
 1. **MP must update the schedule to reflect the TLR curtailment action**
 - **Scheduled amount must match the offered capacity for that resource**



Quick Quiz Question



A resource has several schedules listed for it, but is submitted as an “available” resource. Will the MOS dispatch it economically, or will the MOS dispatch it to the sum of its schedules?



Satisfying Energy Requirements

Example:

- A Market Participant has an obligation of 500 MW at a Settlement Location(s) in a particular hour and two Resources, each having a minimum operating limit of 60 MW and a maximum operating limit of 300 MW.

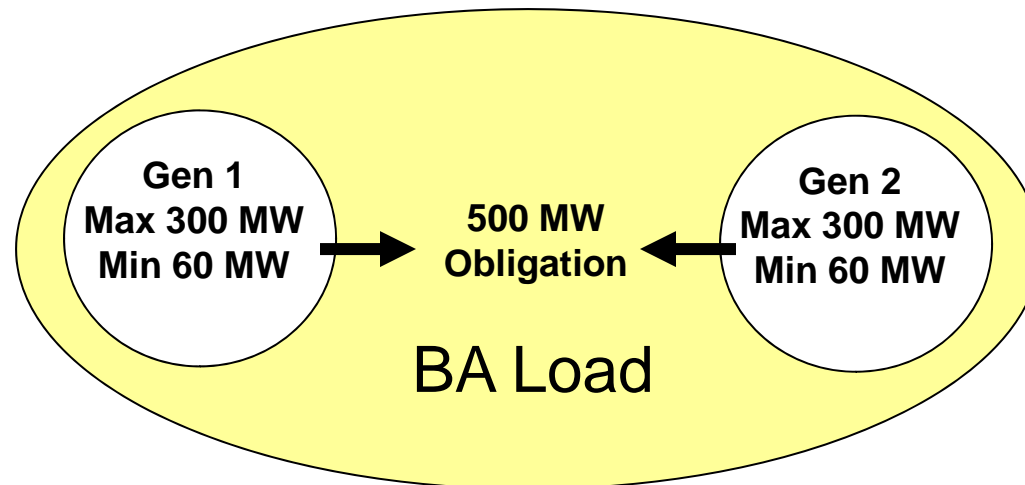



Satisfying Energy Requirements

Self Dispatched

The MP could:

- **Self Dispatch both of its Resources**
- **Indicate it intends to operate its Resources (on its Resource Plan) at an aggregate 500 MW**
- **Generate in real time 500 MW, consistent with the sum of its schedules**
- **The MP must also schedule an aggregate of 500 MW from its Resource Settlement Locations to meet its Load obligations**



Satisfying Energy Requirements

Market Dispatched

OR the MP could:

- Make both Resources available for SPP dispatch
- SPP can then calculate economic base points within the operating range of 60 MW to 300 MW on each unit
- While not explicitly required, the MP could also choose to schedule from its Resource Settlement Locations (and still allow the SPP MOS to dispatch unit)



Satisfying Energy Requirements

OR the MP could:

- Make one of its Resources available for SPP dispatch.
- Self-Dispatch its other Resource by indicating on its Resource Plan that it intends to operate that Resource at 200 MW (and Scheduled as such) and generate in real time at the dispatched 200 MW value.
- Self-Dispatch of the second unit at 200 MW is required so that the remaining load requirements can be covered by the other Resource (made available) being dispatched by SPP MOS
- While not explicitly required, the MP could also choose to schedule from its offered Resource Settlement Location (300 MW).



Reserve Sharing Event

- **Market Participants providing assistance for a reserve sharing event deploy specific Resources at their discretion to respond to the event.**
- **This process will continue in the context of the EIS market.**
- **Schedules of energy deployment from the Reserve Sharing System (RSS) will ensure that Self-dispatched Resources are sent consistent instructions.**
- **Schedules allow the MOS to utilize the withheld capacity from Market Resources allocated as carrying Spinning and/or Supplemental Operating Reserves in the applicable Ancillary Service plans.**



Deployment and Shadow Dispatch

- **Aggregated BA Dispatch is the Aggregated BA "shadow" Dispatch, NOT the deployment dispatch**
 - If the resource is successfully following the deployment value, this value will be identical to the shadow dispatch value.
- **If the self-dispatch resources are not operating to their schedules (or dispatch instruction), the dispatch engine will continue to dispatch them to the sum of their schedules, even if the ramp rate will not allow this instruction to be met.**
 - If the resource cannot meet the deployment value within the set time due to ramp rate limitations, the **Shadow Dispatch** value will indicate where the resource should be, based upon the ramp limitation, thus a difference between the dispatch value and the shadow dispatch value.
- **So if self-dispatch resources are not performing to their schedules, the deployment instructions may not match the value used to calculate the NSI.**



Shadow Dispatch

- **Shadow Dispatch is a resource output value that the SPP MOS expects that resource to be at a specific interval ending per submitted ramp rate.**
 - This is only valid for Self-Dispatched resources
 - Based upon ramp rates for the specific resource
 - Shadow dispatch (not the dispatch instruction) is used for calculation of EI-NSI

Quick Quiz
Question



What must the ramp rate be if the Shadow Dispatch matched the Dispatch instruction?

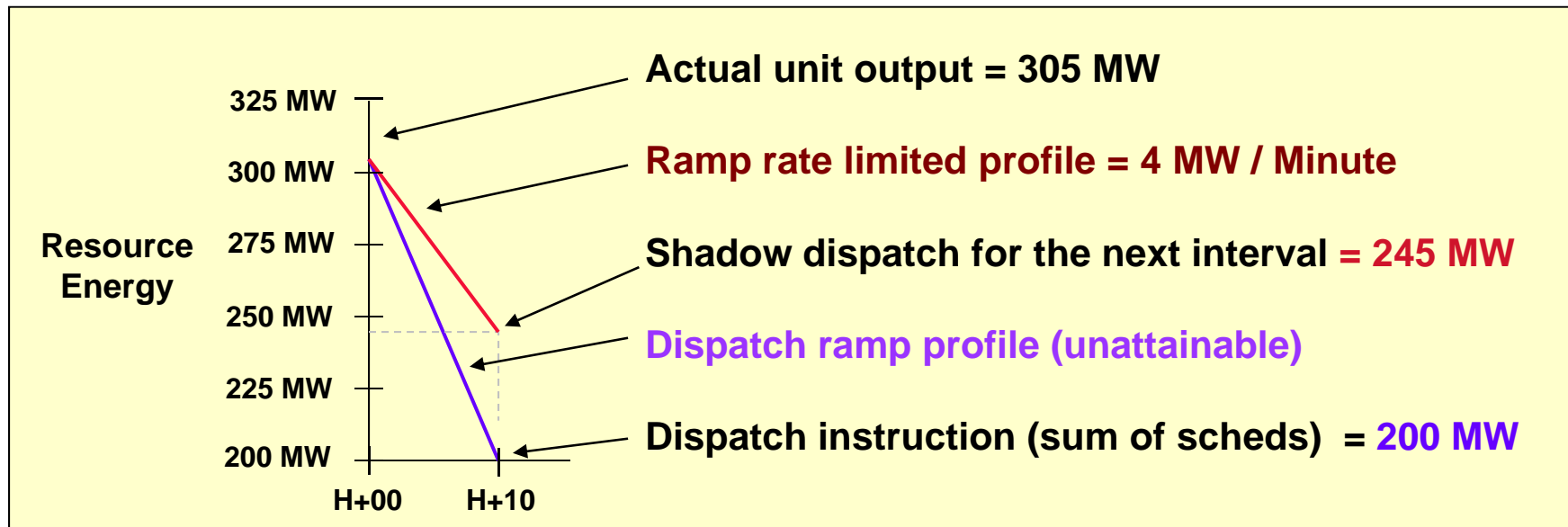



Self-Dispatched Resources Introduction

- **For resources carrying spin and supp capacity, the intervals during an SPP Automated Reserve Sharing event will be ignored for the purposes of determining uninstructed resource deviation.**



Quick Quiz Question



Is a Self-Dispatched resource subject to Energy Imbalance Service?



Markets 301

TLR and Congestion Management



CM Tool Development and Rationale

- **With the implementation of an energy market not all schedules/tags represent physical/actual flows.**
- **Due to SPP's use of schedules as a physical transmission rights, SPP has developed the **Curtailment Adjustment Tool (CAT)****
 - **Used in the curtailment of Market Schedules**
- **Market Schedules could be compared to the NNL obligation for non-market entities.**
- **Market flow is then sent to NERC IDC**
 1. **NH-EIS Study provides this data every 15 minutes**



Transmission Loading Relief (TLR)

- **TLR is broken down into two types of constraint flow and relief .**
 - **Those handled by the NERC IDC using transaction curtailment relief**
 - **Those handled by the Market using SCED (and Market schedule curtailments - using CAT)**
- **Tools have been developed that allows NERC IDC to view both transaction impacts, and SPP Market flow impacts to these constraints.**
 - **During TLR, NERC IDC will provide SPP with required relief based upon both types of constraint flow.**
 1. **Transaction flow**
 2. **Market flow.**

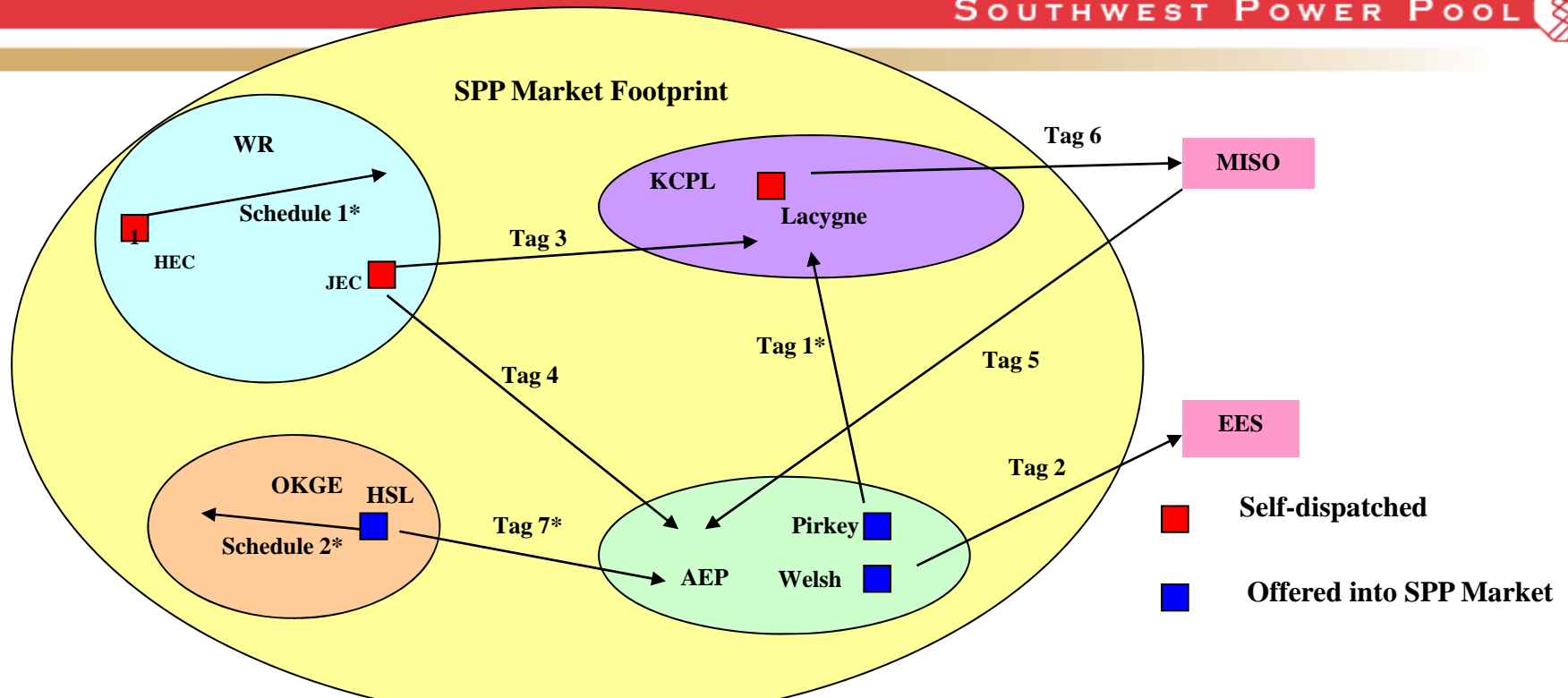

<i>Tag/Schedule</i>	<i>Source</i>	<i>GCA</i>	<i>LCA</i>	<i>Sink</i>	<i>Schedule Type</i>	<i>Curtailment Tool</i>
Tag 1	Pirkey	AEP	KCPL	KCPL	Market	SPP CAT
Tag 2	Welsh	AEP	EES	EES	Market	NERC IDC
Tag 3	JEC	WR	KCPL	KCPL	Physical	NERC IDC
Tag 4	JEC	WR	AEP	AEP	Physical	NERC IDC
Tag 5	MISO	MISO	AEP	AEP	Physical	NERC IDC
Tag 6	LaCygne	KCPL	MISO	MISO.CIN	Physical	NERC IDC
Tag 7	HSL	OKGE	AEP	AEP	Market	SPP CAT
Schedule 1	HEC	NA	NA	WR	Physical	SPP CAT
Schedule 2	HSL	NA	NA	OKGE	Market	SPP CAT



Quick Quiz Question



Any schedule not currently seen and processed by the NERC IDC is handled by _____



TLR Operations

- **Reducing constraint flows through TLR is comprised of two types of curtailments:**
 - **NERC IDC tag curtailments**
 1. NERC IDC Cut or reduced tagged flow during a TLR
 2. SPP will acknowledge these tag curtailments
 3. Participants to the tags will respond to curtailments
 4. Same as the Pre-Market curtailment process using IDC only

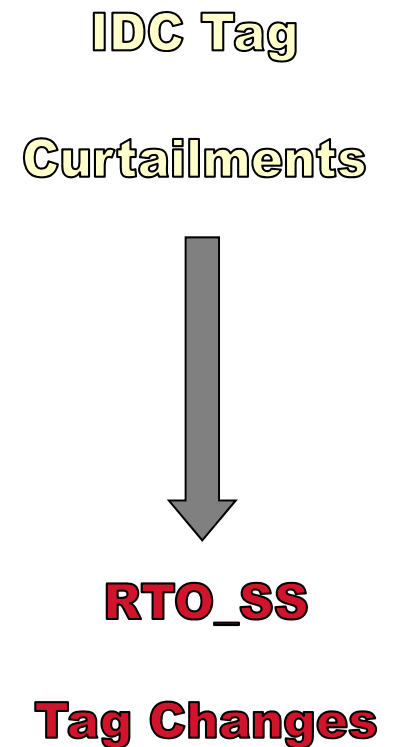

TLR Operations

- **Reducing constraint flows through TLR is comprised of two types of curtailments:**
 - **NERC IDC Market flow relief**
 1. IDC also communicates the required Market flow reductions to SPP via the NERC IDC during a TLR
 2. The SPP CAT (Curtailment Adjustment Tool) is used to curtail Market flow schedules
 3. EIS curtailed first (for same IDC priority curtailed)
 4. CAT will send schedule adjustments to RTO_SS for viewing by the parties to the transactions

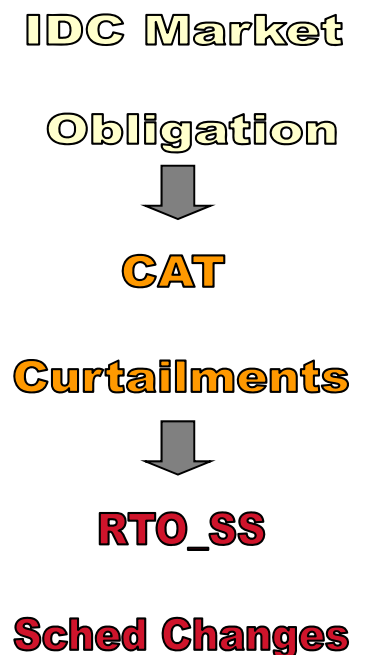

TLR Operations

Source	Source BA	Sink	Sink BA	Adjusted by:
Available	SPP BA	External	External BA	IDC
Self-Dispatched	SPP BA	External	External BA	IDC
Self-Dispatched	SPP BA	Load Settlement Location	SPP BA	IDC
Load Settlement Location	SPP BA	External	External BA	IDC
External	External BA	External	External BA	IDC
External	External BA	Load Settlement Location	SPP BA	IDC
Available	SPP BA	Load Settlement Location	SPP BA	CAT
Self-Dispatched	SPP BA	Load Settlement Location	SPP BA (where GCA = LCA)	CAT
Load Settlement Location	SPP BA	Load Settlement Location	SPP BA	CAT



TLR and Self-Dispatched Resources

- If TLR is called, schedules involving Self-Dispatch resources will be subject to curtailment like all others.
- All Inter-Control Area schedules involving a self-dispatched resource will be curtailed by the IDC. Any intra-control area schedules within the market would be curtailed by the SPP Curtailment Adjustment Tool (CAT).
- Since the dispatch instruction of a self-dispatch resource is driven completely by the sum of the schedules, any curtailment by IDC or CAT will be reflected in the next dispatch.

Curtailment → RTO_SS → MOS Dispatch



Quick Quiz Question



In Congestion Management and the TLR process, what two types of constraint flow are considered when IDC issues relief obligation?



Market 301

Net Scheduled Interchange (NSI)



Net Scheduled Interchange (NSI)

- **What is Net Scheduled Interchange (NSI)?**
 - **NSI is the algebraic sum of all energy scheduled to flow into or out of a settlement area during a settlement interval. NSI includes the ramp on a 4 second interval to achieve the dispatch instructions by the end of the deployment interval.**
- **The [Market \(MOS\) NSI](#) calculation includes the total energy transfer for each control area.**
 - **This includes the two components related to energy imbalance and schedules.**
 1. **Scheduled Interchange**
 2. **Market interchange (economic dispatch or EI)**



Net Scheduled Interchange (NSI)

- The **Scheduling (RTO_SS) NSI** component calculation is the net of all schedules for a specific control area every four seconds.
- The **Energy Imbalance (EI)** interchange is the component of the MOS NSI that does not include scheduled flows.
 - Represents only the energy imbalance portion.

(EI) + (Real-time RTO_SS NSI) = Net Market NSI to Control Areas

Components of MOS NSI

Comparing RTO_SS NSI, EI NSI, and MOS NSI

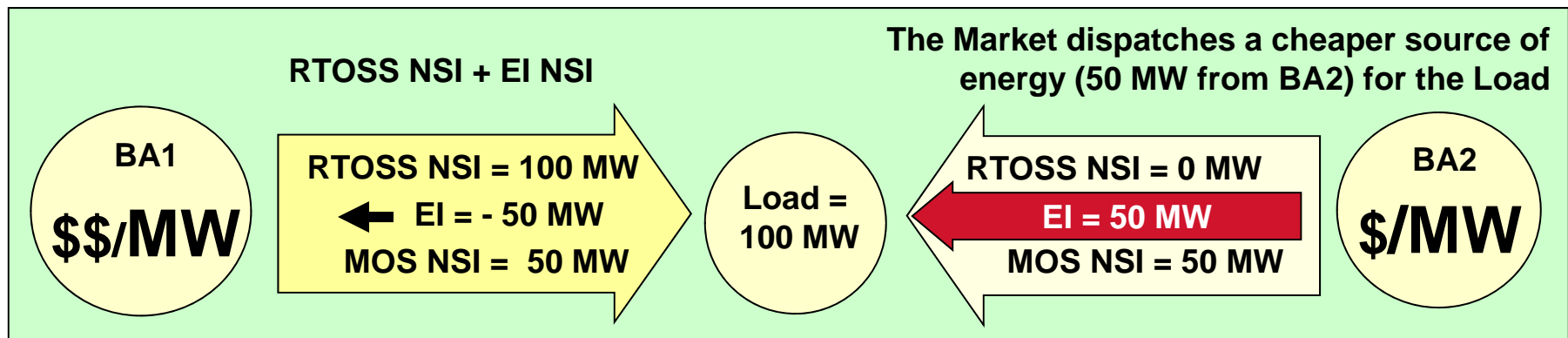
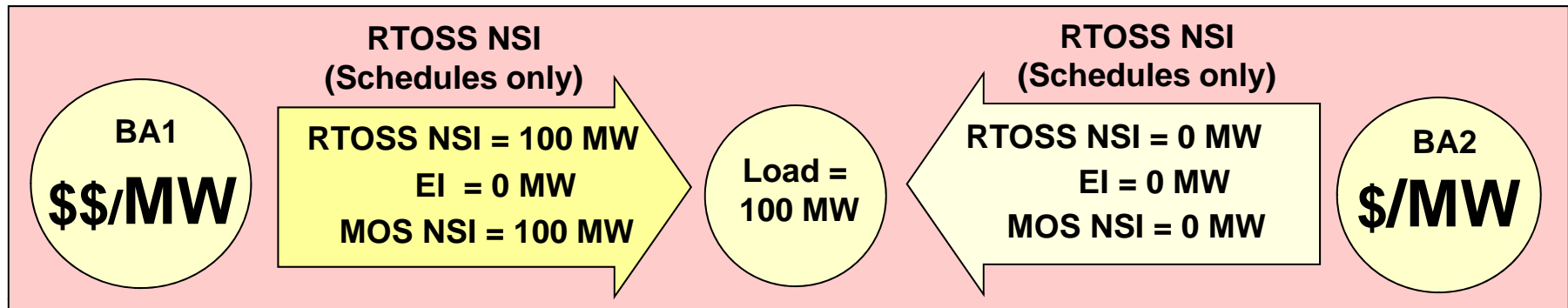

As a result of the Market economic dispatch, the originally scheduled 100 MW NSI for BA1 was decreased by 50 MW (- 50 MW EI) for a new MOS NSI total of 50 MW.

Also, the MOS NSI for BA2 increased from the originally scheduled 0 MW as a result of the Market economic dispatch to now supply 50 MW to the load



Quick Quiz Question



The final MOS NSI value provided to our participants is derived from what two kinds of interchange values?



The Big Picture



- **How are the EI interchange values calculated?**
 - MOS calculates SPP NSI from RTO_SS schedules

SPP RTO_SS NSI

- **SPP RTO_SS NSI + sum of all BA load forecasts (entire SPP load) = Economic Dispatch for entire Market footprint**

Dispatch value for ALL SPP Resources



The Big Picture



- How are the EI Interchange values calculated?
- Single *BA* generation (**Shadow dispatch**) – single *BA* forecast = Market NSI for that *BA*

Balancing Authority Total NSI signal

- $BA \text{ Market NSI} - BA \text{ RTO_SS NSI} = BA \text{ EI Interchange}$

Balancing Authority EI Interchange



The Big Picture



- **How are the EI Interchange values calculated?**

MOS sends this balancing authority EI Interchange to the SPP EMS (RTSMGR)

Dynamic schedules are excluded at this point

Where it is combined with the RTO_SS NSI (one minute NSI calculation)...

Total or MOS NSI as seen by the MP

Resulting in the calculation of a four second MOS (total) NSI value for the BA

- Resource Actual output = 310 MW
- Resource Dispatch instruction = 200 MW
- Resource Shadow Dispatch = 250 MW
- Resource Scheduled output = 200 MW
- Load Forecast = 300 MW
- RTO_SS interchange = -100 MW (import)

What are the assumptions?

- Unit status
- Number of units

Important key: Shadow dispatch is used for EI Interchange, but not for EI calculations

$$\begin{array}{rcl}
 250 \text{ MW} & - & 300 \text{ MW} & = & - 50 \text{ MW MOS NSI} \\
 \text{Shadow Dispatch} & - & \text{Load Forecast} & = & \text{Total NSI}
 \end{array}$$

$$\begin{array}{rcl}
 -50 \text{ MW} & - & (-100 \text{ MW}) & = & 50 \text{ MW EI Interchange} \\
 \text{Total NSI} & - & \text{RTO_SS NSI} & = & \text{EI NSI}
 \end{array}$$

Determining EI NSI

1850 MW – 1500 MW = 350 MW
 Single BA gen – Single BA LF = Single BA MOS NSI

350 MW – 0 MW = 350 MW
 BA MOS NSI – BA RTO_SS NSI = BA EI NSI

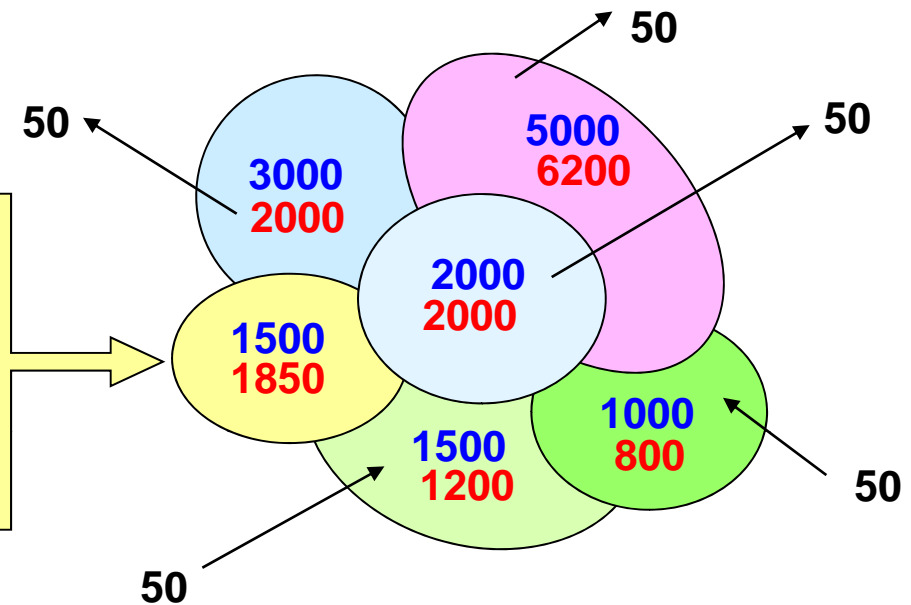

- Total SPP (footprint) RTO_SS NSI = + 50 MW (+150 – 100 = 50)
- Sum of all BA load forecasts = 14000 (SPP calculated value)
- Total SPP NSI + ΣBA forecasts = **Economic Dispatch** for each resource to supply its share of the total 14050 MW required for the SPP footprint
- **Single BA generation** – **single BA load forecast** = single BA Market NSI
- BA Market NSI – BA RTO_SS NSI = BA EI NSI

NSI Summary

MOS (Total) NSI is the net of:

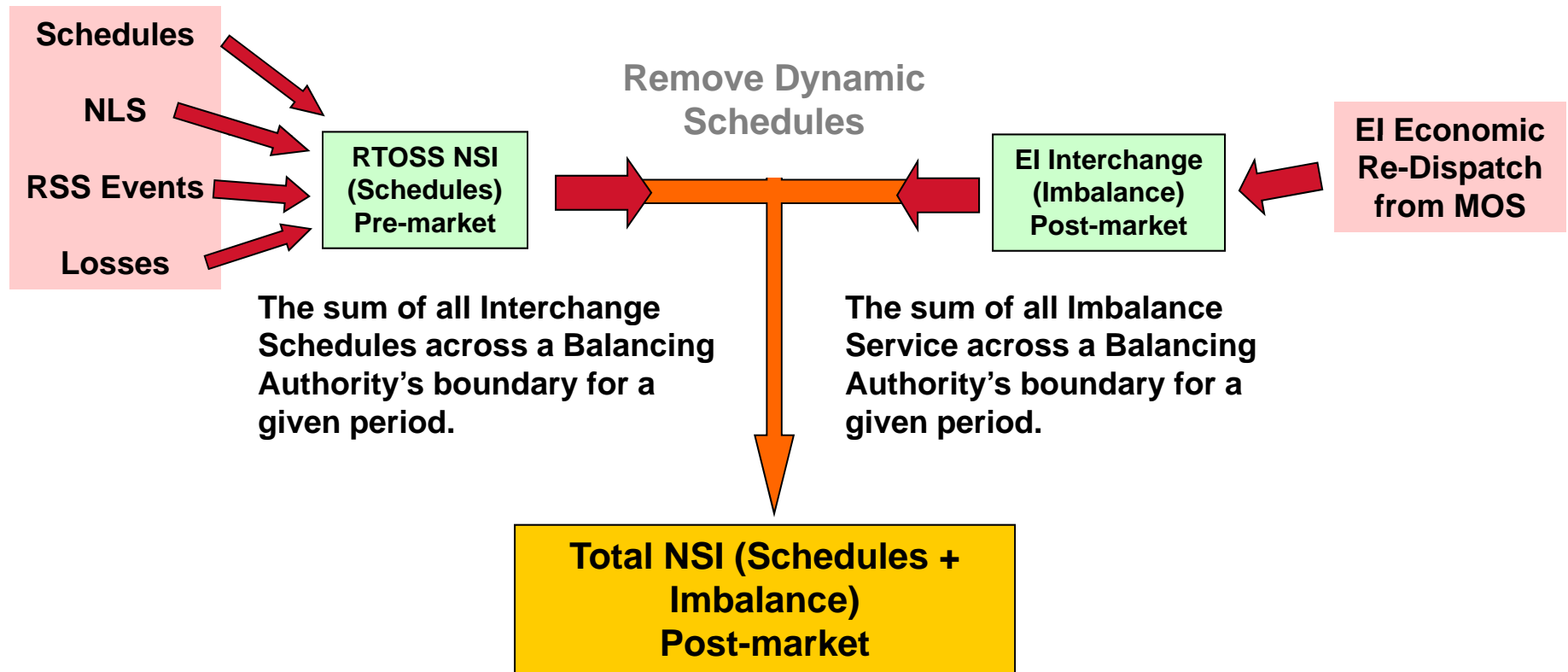



Self-Dispatch and NSI

- **It is important for BAs to control to the NSI they receive from SPP first and foremost and then drive their units to the base point as best they can.**



Markets 301

SFTDA

(Simultaneous Feasibility Test Deliverability Analysis)



SFTDA



- **Purpose**
 - **SFTDA studies determine the deliverability of energy resources to serve energy obligations**
 - **Is it feasible for this set of generators to supply that load without causing constraints?**
 - **If not, what is causing the constraint, and what action is needed to mitigate it?**



SFTDA

- **SFTDA (or Deliverability) is based upon:**
 - **RP (reflects which resources can be used)**
 - **Offer Curves (reflects resource output through dispatch instruction)**
 - **Schedules (expected flows)**
 - **SPP Load Forecast for each BA**
 - **Monitored single element transmission facilities (N-1 contingency study)**



Result? What, if any, constraints have been identified by this study?



SFTDA

- **SFTDA run from the Congestion Management Report**
- **Violation information will be sent to the appropriate MP and host BA via the portal**
 - **Violation Infeasible status denotes constraint could not be controlled using the current RP information**
 - **Self Dispatched resources set to Available for the purpose of finding a solution to the violation**
 - **MW amount of relief obligation to the MP is included in the SFTDA report**





Markets 301

Supply Adequacy Analysis



Supply Adequacy

- **What does the Supply Adequacy study do?**
 - Verifies the MPs have sufficient energy to meet load obligations
- **Supply Adequacy study is based upon:**
 - Load Forecast
 - RPs
 - AS plans
 - Schedules received from MPs



Supply Adequacy

- **Supply Adequacy is run 1500 day prior**
 - **Over / Under Sufficiency information will be sent to the appropriate MP and host BA**
 - **Market participant shall remedy the situation by 1700 day prior**
 1. **Checks / changes no later than OH-45 minutes**





Supply Adequacy Process

Load + Sales – Purchases = Energy Obligation



MinMW < Energy Obligation < MaxMW



If false: Notify inadequate MP and Host BA



MP Shall update Load Forecast, Resource Plan, or Schedules



Markets 301

Settlements



Introduction to Settlements

- **The purpose of the settlement process is to:**
 - **Calculate quantity of energy imbalance for each asset**
 - **Calculate invoice dollars for energy imbalances**
 - **Allocate over- and under-collection of revenues to asset owners**



Introduction to Settlements

- **Each registered asset becomes a settlement location.**
- **Resources will be settled based on LIP associated with their settlement location.**
- **Load may choose to be settled either zonally or nodally.**
- **Resources that are self-dispatched will be responsible for any imbalance charges. They cannot “opt out.”**
- **The market will be facilitated such that SPP will remain revenue neutral.**



Introduction to Settlements

- **Settlement statements will be produced and published for each operating day.**
- **SPP will utilize the best available data for settlements at the time each settlement statement is run which may be a combination of actual and estimated data.**
- **Invoice for a single operating day will have both an initial and final statement, and may contain a resettlement statement.**
- **Statements will provide the billing determinants for each operating day.**



Post Operating Hour Market Activities

- **At 15 minutes after the operating hour (OH +15), SPP:**
 - **Creates a file of Locational Imbalance Prices (LIP) and posts the file on the www.spp.org website.**
 1. **The file is available for query on the Portal and will only display information for the MP's registered assets.**



Updates to Operating Day Data

- **To ensure the most accurate schedules are created and submitted, schedule updates may be necessary.**
 - **Reserve Sharing System (RSS) Event by 0100 of OD+3.**
 - **Bilateral Dynamic Schedules - Submitted by 0100 of OD+3.**



Quick Quiz Question



Schedules for an RSS event may be submitted or modified up to how many days after the event?



Post Operating Day Market Activities

- **By 4 days after the operating day:**
 - **MPs submit load, generation, and interconnection meter data.**
- **By the end of the 7th day after the operating day:**
 - **SPP prepares initial settlement statements by settlement location, hour, and Market Participant and posts these on the Portal.**
- **By 45 days after the operating day:**
 - **SPP prepares final settlement statements by settlement location, hour, and Market Participant and posts these on the Portal.**



Markets 301

Market Monitoring & Mitigation



Introduction to Market Monitoring

- **Requirement** - Market monitoring and mitigation is an essential function for Regional Transmission Organizations (RTOs) and is required by FERC Order 2000.
- **Purpose** - Monitor and mitigate the potential exercise of horizontal and vertical market power by participants in SPP Markets.
 - Specific resource may be only solution to solving a constraint issue



Functional Responsibilities

- **Design and implement market mitigation measures for Spot Balancing Market and the Transmission Services Market**
- **Conduct inquiries requested by market participants or initiated by the Market Monitors**
- **Monitor and assess market design for weaknesses or failures and recommend changes**



Market Mitigation

Offer Caps - Spot Balancing Market

- **Designed to mitigate the potential exercise of market power**
- **Offer Caps are imposed only at times of transmission constraints**
- **Do not mitigate below long-run marginal cost of new investment**
- **Limited to Resources that are within electrical proximity of a constrained flowgate**



Markets 301

Multiple XML Listeners



XML Listeners

- **Additional Market Participant Listeners (Multiple listeners)**
 - **SPP will not filter (segregate) instructions among different listeners for same Market Participant**
 - **Additional listeners will receive all data for all assets registered under that same Market Participant.**
 - **Resource owner responsible for filtering data against other resources on extra listeners if desired.**
 - **A maximum of 10 listeners will be allowed per Market Participant.**

XML Multiple Listeners

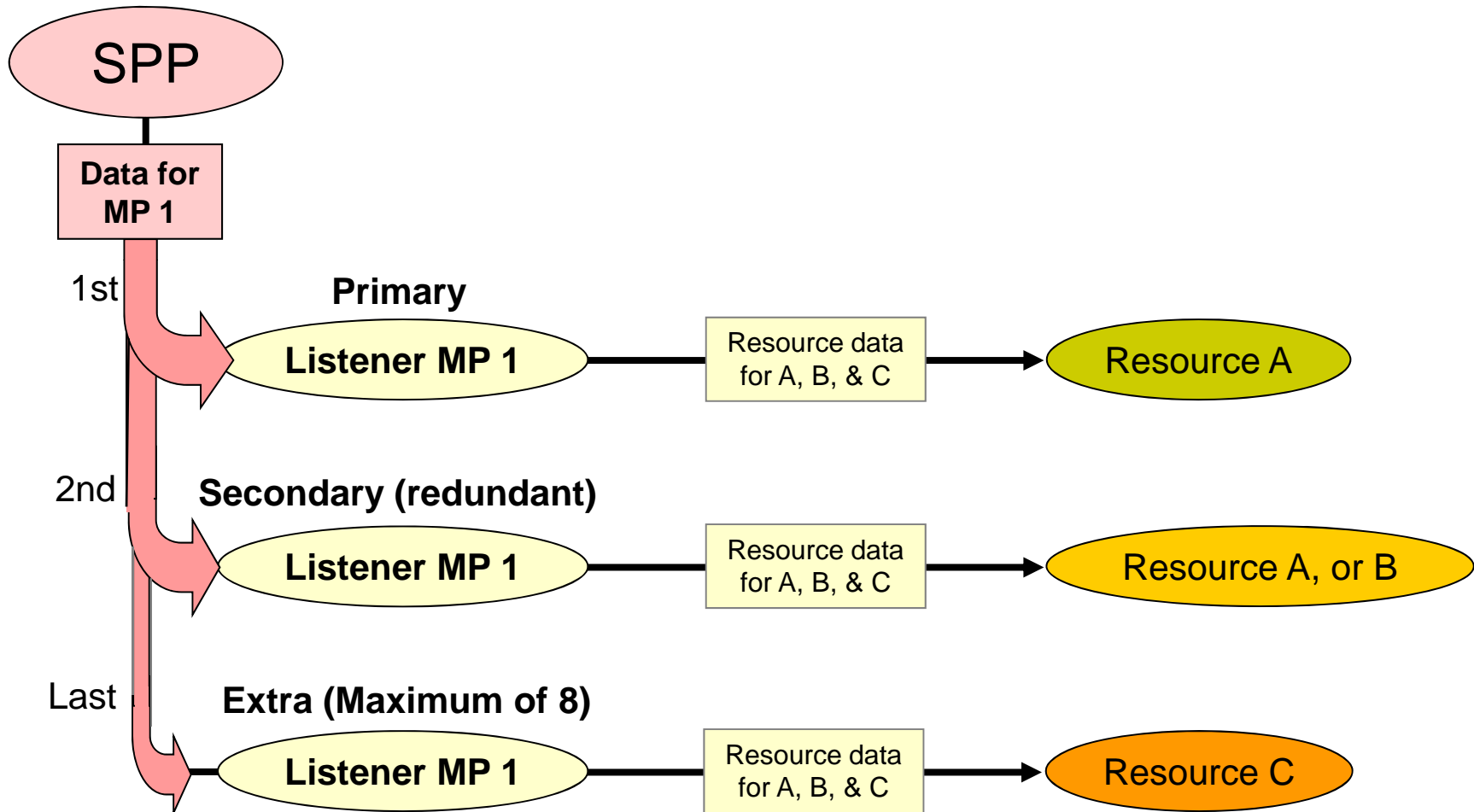



Questions?

Manager Market Operations: sellis@spp.org

Supervisor Market Operations: cbrown@spp.org

Supervisor Performance Support: toxandale@spp.org