

***Centralized Remedial Action Scheme
(C-RAS) using Emerging
Telecommunication (IEC61850),
Protection Technologies, and OSIsoft
Controller software***

**Dana Cabbell / Shashi Pandey
Southern California Edison Company**

**Colorado Transmission Planning Meeting
September 17, 2008**

SCE T&D Assets

Generation

Transmission & Subtransmission

Distribution

Customer

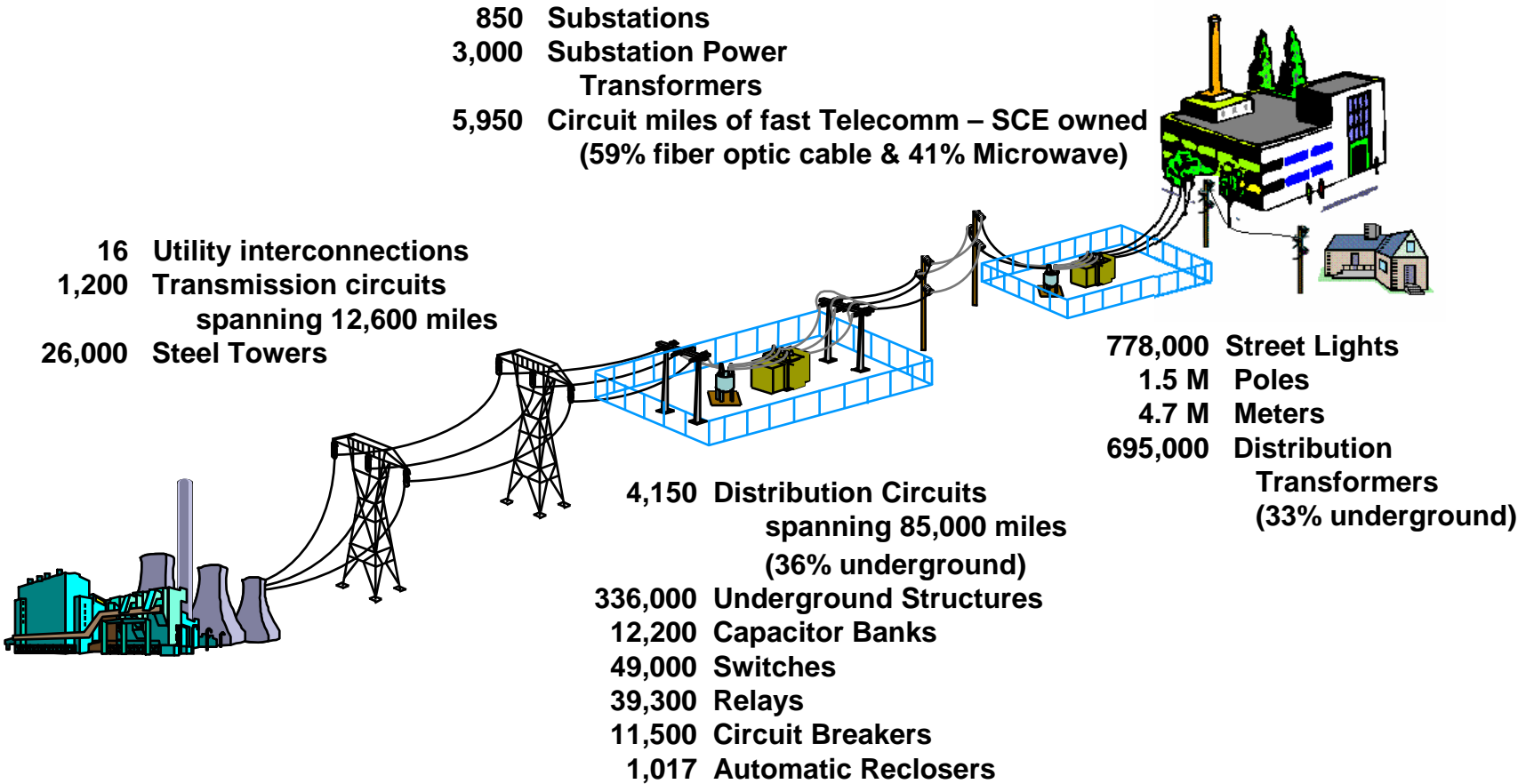

SCE Transmission Network

Key Transmission Planning/ Operational Issues

- Congested transmission corridors/
network
 - Ever increasing customer load growth
- Long lead time to build transmission
 - Transmission lagging generation and customer load growth
- Integration of new generators including
renewables into the transmission
network
 - Uncertainty on new generation
siting/locations
 - Legislative/regulatory renewable
targets mandate
- Increasing transmission voltage
support requirements
- Extensive use of “Remedial Action
Schemes (RAS)”

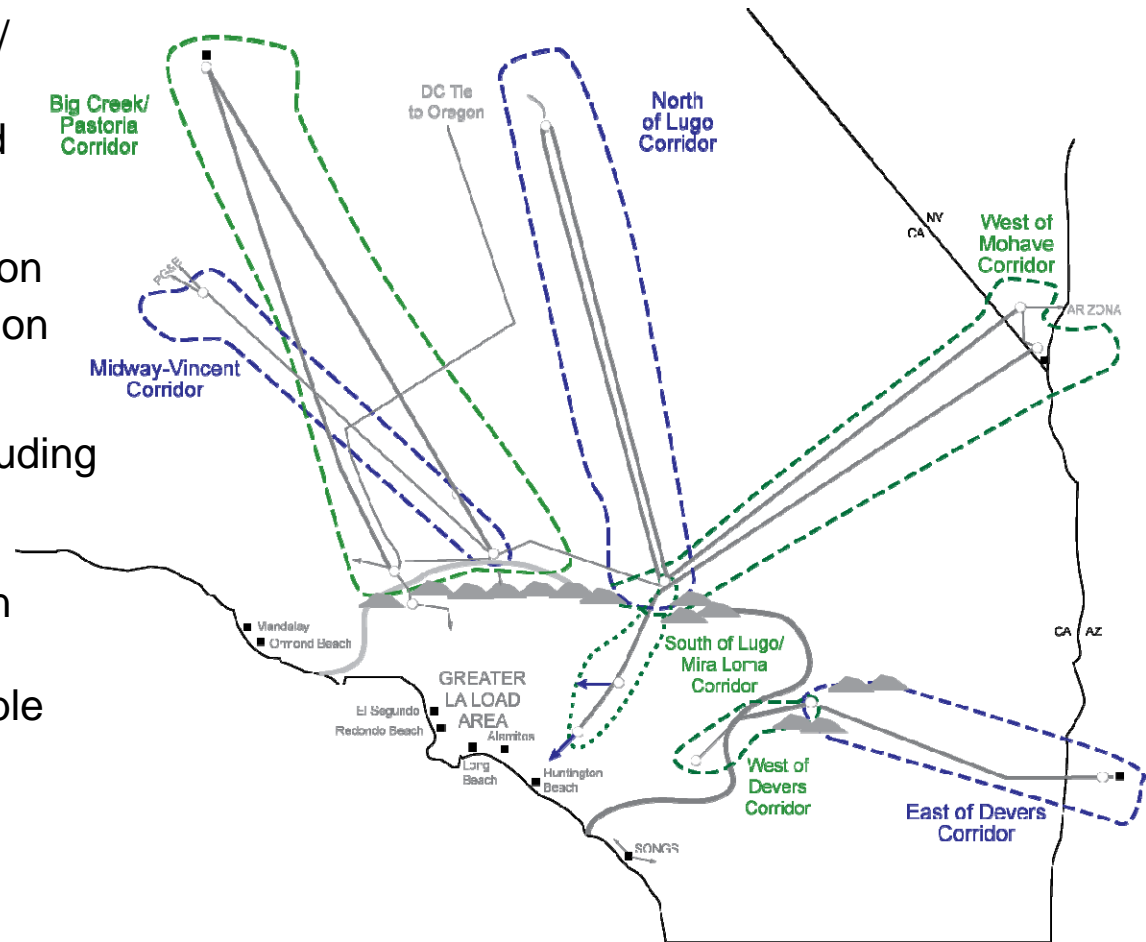

What is a Remedial Action Scheme (RAS)?

- **Remedial Action Scheme (RAS) is also known as System Integrity Protection Scheme (SPS)**
- **Definition:**

A set of fast and automatic control actions, utilizing protection relays and fast telecommunications network, to ensure acceptable (reliable and safe) power system performance following critical outages on a transmission grid network
- **Purpose:**
 - Mitigates thermal overload and/or instability problems following the loss of one or more transmission lines or transformers in a transmission corridor
 - Protects the power grid system from disturbances that would otherwise cause a cascading outage or major degradation in power system security
- **Functionality:**
 - Monitors System Conditions including flows on critical lines or transformers
 - Detects an “Event” such as a line or transformer outage
 - Determines pre-planned mitigation (generation tripping or load shedding)
 - Sends “Mitigation” signal to appropriate location (i.e., opening of circuit breakers at substations)

SCE Transmission Corridors and Proliferating RAS Schemes

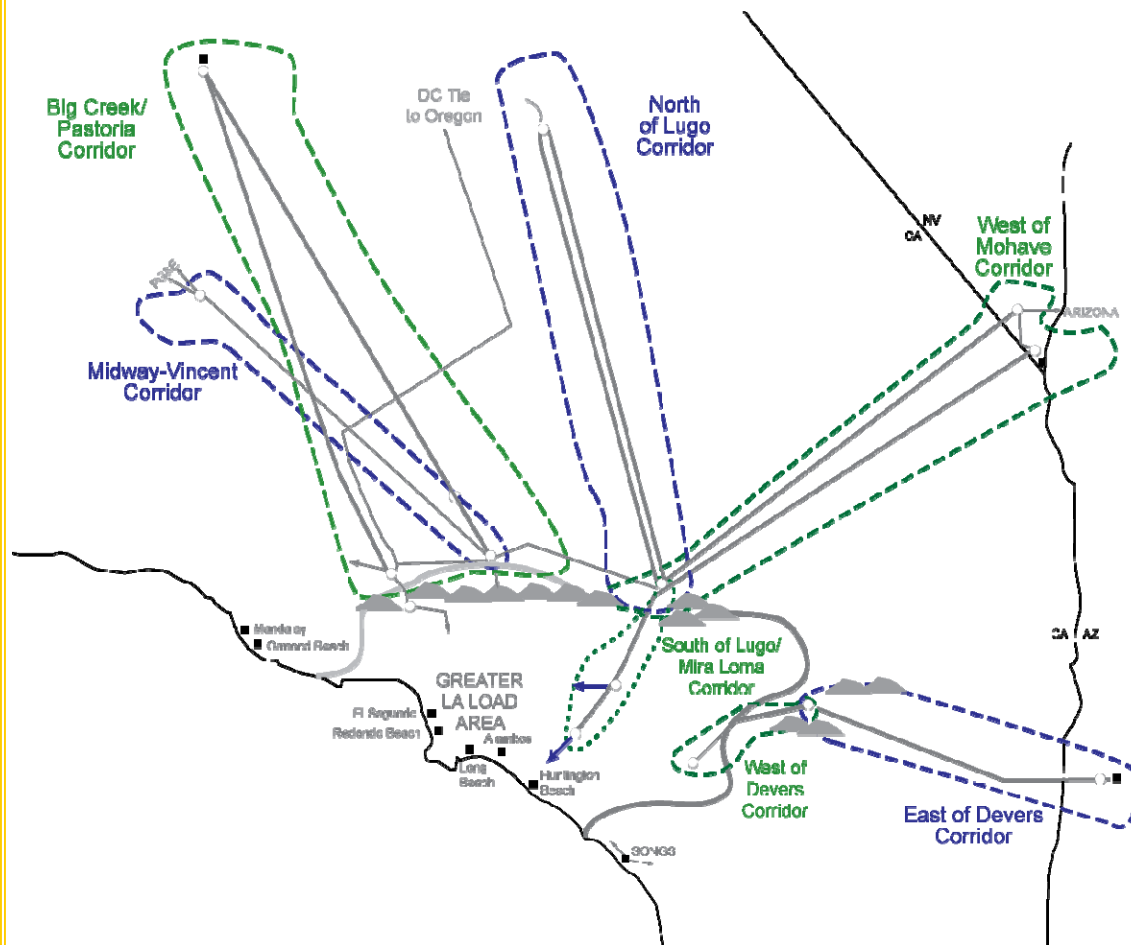

- Existing RAS = 17 on all transmission corridors
- Expected potential new RASs (2007-2009) based on CAISO Queue = 57
- RAS impacted transmission – Mitigation methods
 - Generation tripping
 - Load shedding

Voltage	Miles of Transmission Circuits	
	Total Miles	RAS Monitored (%)
500 kV	1,183	1,069 (90% of mi.)
230 kV	3,574	1,181 (33% of mi.)
115 kV	1,846	350 (19% of mi.)
All	6,603	2,600 (40% of mi.)

Key Observation: Almost all bulk power lines bringing generation / imports into the greater Los Angeles basin load area are being monitored for contingencies and flow levels, and controlled by local RAS schemes.

Existing RAS and Expected New Generators Requiring RAS Schemes – Locations

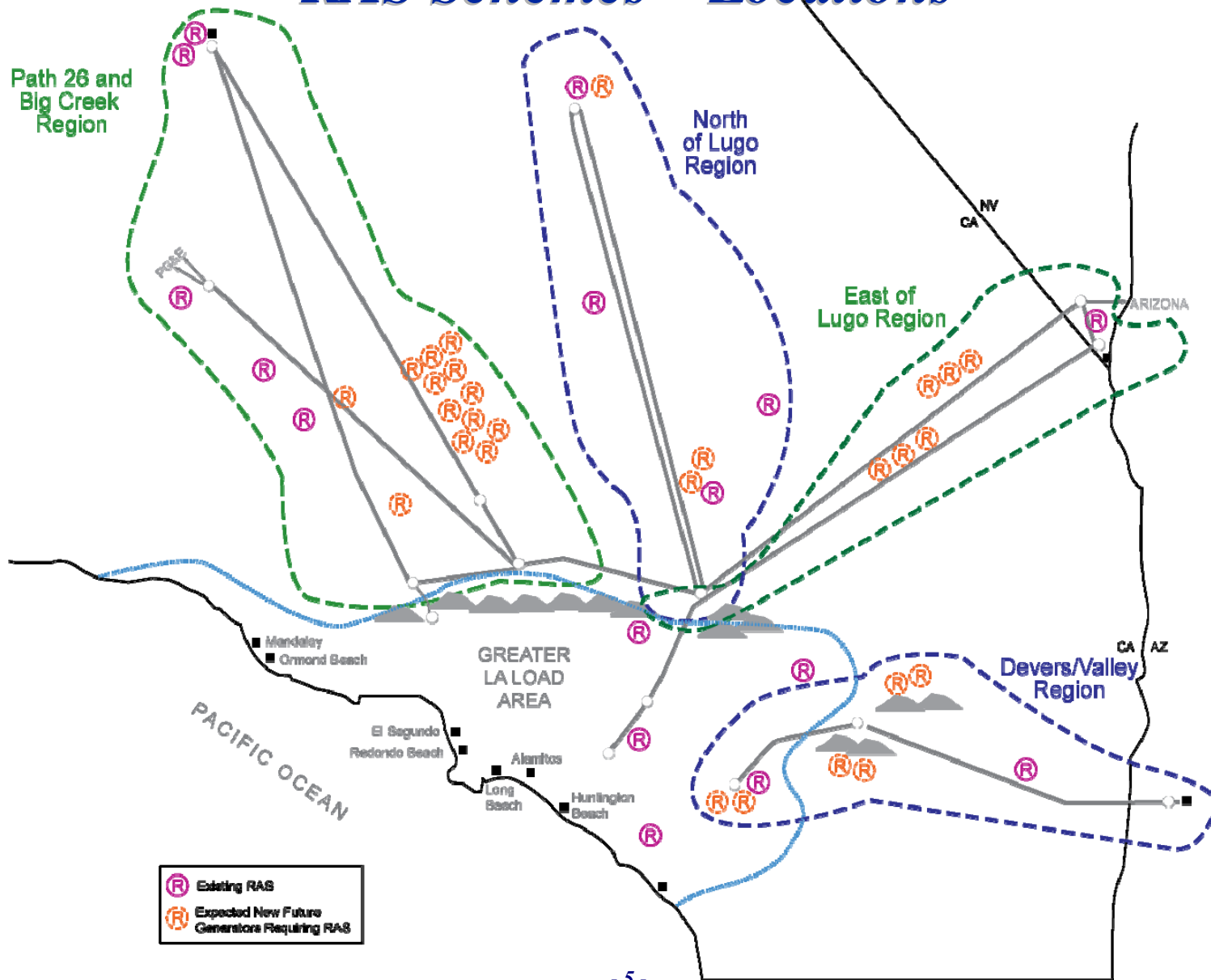

Existing South of Lugo (SOL) Remedial Action Scheme

■ South of Lugo (SOL) RAS Attributes

1. Protects against post-transient voltage instability and/or thermal overloads for any N-2 line outage contingencies on the corridor
2. Monitors SOL path flows limit with RAS in service and without RAS
3. Mitigates N-2 line outage contingencies by shedding load at Chino, Mira Loma and Padua
4. Utilizes Automatic Arming Application Program (AAP) running on EMS computer at GCC, Alhambra
5. Accesses dual path Redundant Telecommunication Circuits (fiber and microwave)
6. Runs on redundant SEL-2100 Logic Processors at Mira Loma
7. Meets WECC RAS Redundancy criteria

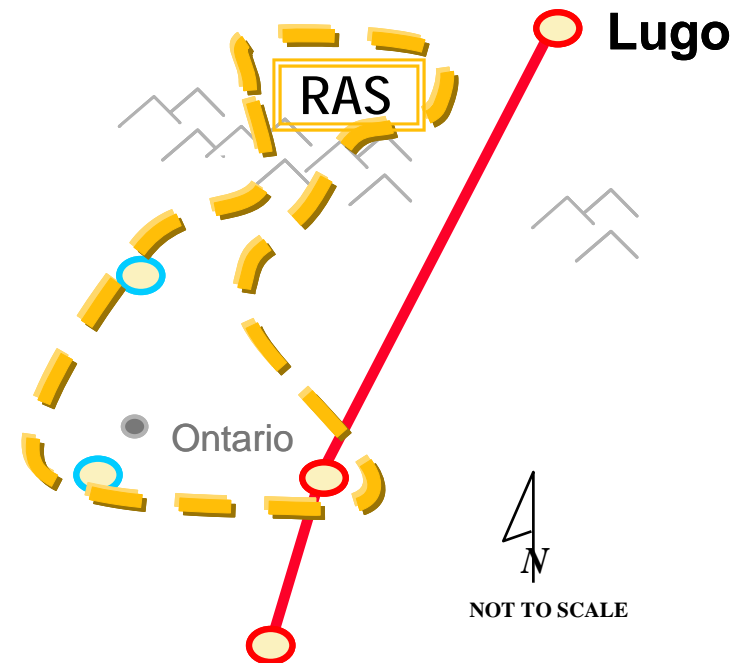

Existing South of Lugo (SOL) RAS Layout of Telecomm Infrastructure, Relays and Logic Processor

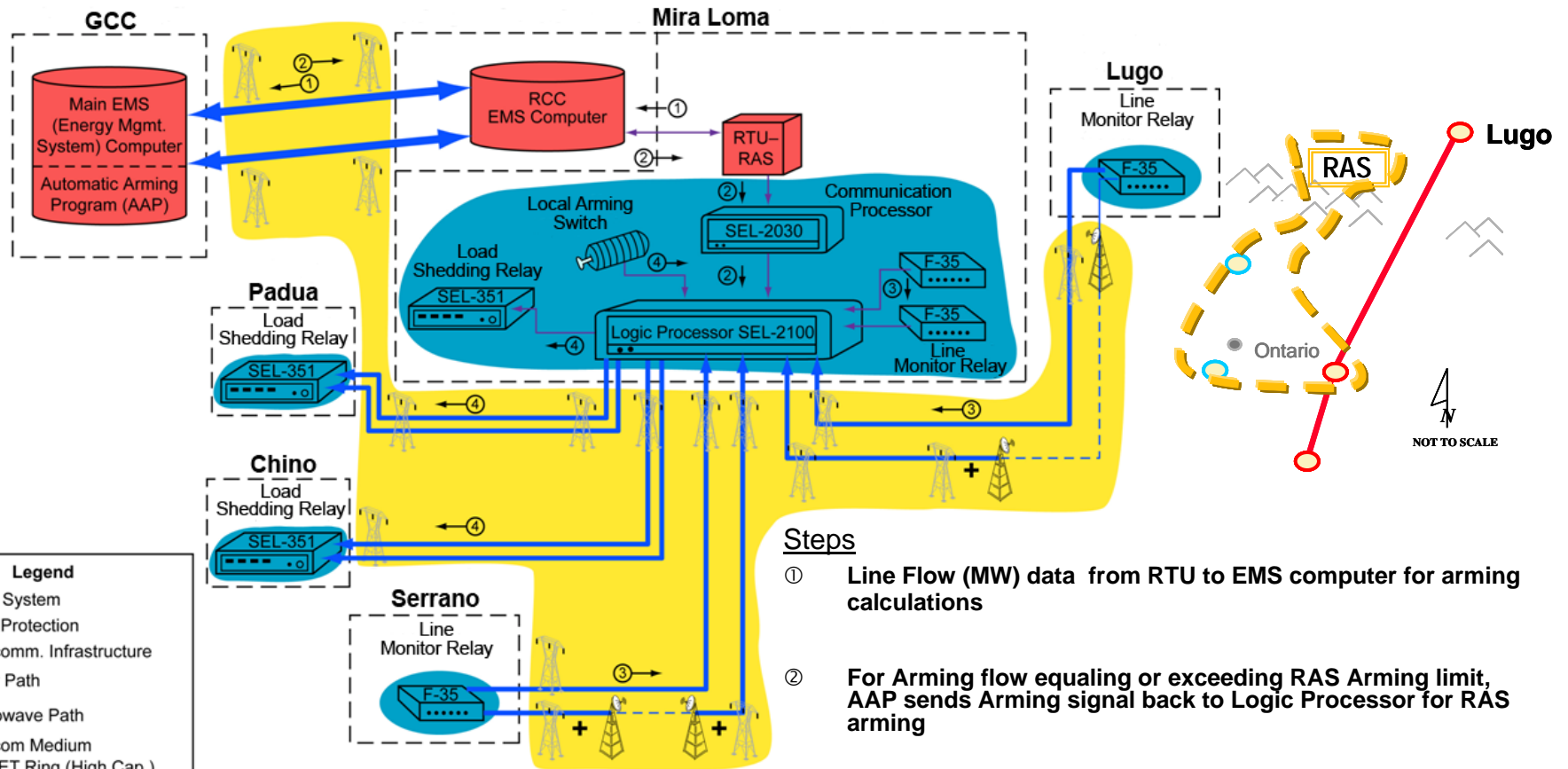

Steps

- ① Line Flow (MW) data from RTU to EMS computer for arming calculations
- ② For Arming flow equaling or exceeding RAS Arming limit, AAP sends Arming signal back to Logic Processor for RAS arming
- ③ Monitoring of N-2 Outage and sending Confirmation to Logic processor
- ④ If RAS is armed & N-2 line Outage is confirmed, Logic processor sends Mitigation signals to drop load at Padua, Chino & Mira Loma

C-RAS: Application of Emerging Telecommunication + Protection Technologies

- **Solves today's RAS problems:**
 - **ONE SIZE FITS ALL:** Inability to size a RAS driven mitigation targets based on dynamic assessment of generation tripping / load shedding requirements
 - **OVERLAP:** Same Generation / Load subject to interruption for numerous reasons controlled by different RAS' and other reliable and safe operational requirements
 - **TIME LOSS:** Excessive travel time by engineering and field staff to maintain the local RAS schemes at numerous sites
 - **CONTROLLER TECHNOLOGY LIMITATIONS:** Inability to represent greater than 24 contingencies per RAS controller today
- **Leverages SCE's extensive Fiber / Microwave Telecomm Backbone**
- **Adopts Emerging Technologies to achieve higher performance**
 - IEC61850 GOOSE Standard (Ethernet Platform to move data packets fast)
 - General Electric IED: N-60 with synchrophasor capability
 - OSIsoft PI Historian software for C-RAS Controller
 - SISCO GOOSE (Generic Object Oriented Substation Event) Management Software Tools for C-RAS computational needs

Why is C-RAS fast?

- **Fiber / Microwave based platform**
 - Speed
 - Accuracy
 - Redundancy
- **Connects all SCE major substations and generating plants**
- **Offers a controller with high speed, redundant, industrial, and Windows based processors**
- **Allows standardized data packet format over Ethernet packed with grid information**
- **Utilizes standardized industry leading communication protocols with dedicated 1.6 MB T1 data transmission capacity**
 - No longer point-to-point 64 KB mirrored bit data transmission

Key Requirements for C-RAS Scheme Testing

A. Protection/Computing/Data Packets Over Ethernet Protocol

- 1. Line Flows for Arming → PMU
- 2. Line Outage Detection → Relay
- 3. Logic Processing with GOOSE Data Packets → Computer
- 4. Mitigation Action Signal → Relay



GE N-60 Universal Relay



Capabilities:

- Synchrophasor Phasor Measurement Unit (PMU)
- Outage/Mitigation relay functions
- CPU processor with GOOSE data packets



Pilot C-RAS Controller equipment components at SGLS*

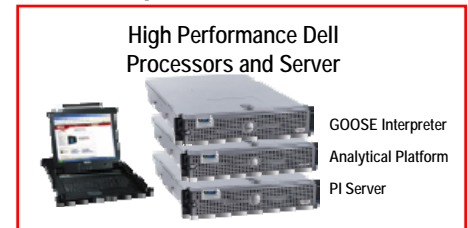

Capabilities:

- GOOSE Data Packet Interpretation
- RAS Logical Calculations
- RAS Arming Calculations
- RAS Mitigation Calculations
- Archiving and retrieving time stamped data values

B. Telecommunication Infrastructure Reuirements

- 1. Availability of Telecomm. Circuits to all major substations in each corridor → Two T1 circuits for each corridor
- 2. Adequate Bandwidth and Speed for GOOSE Data Packets → T1 = 1.544 Mbps
- 3. SCE Network distances to be covered → 100 – 660 miles
- 4. Desired Speed for C-RAS → < 50 ms

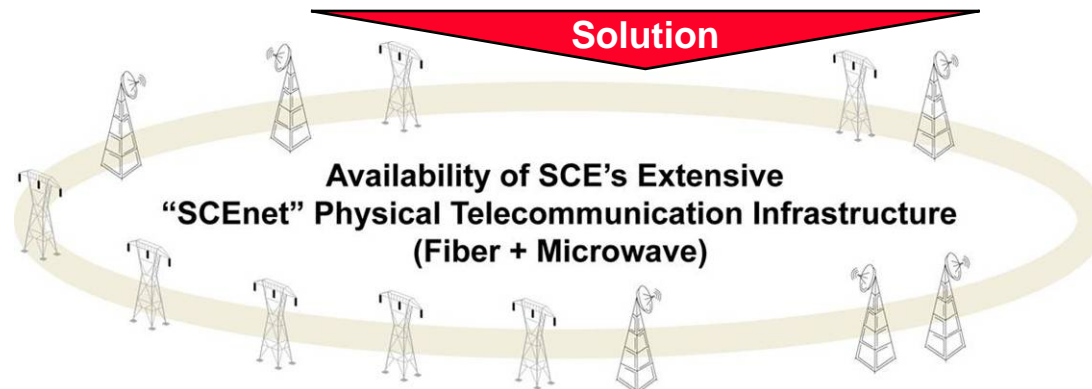

*Smart Grid Lab Setup

Technology Evolution

Technologies	Existing RAS	Proposed C-RAS
Telecomm Infrastructure	Dedicated Point-to Point Channel (64k)	Ethernet WAN (T1=1.544 mbps)
Data Transmission	Digital Mirrored Bit Transfer	IEC61850 GOOSE Data Packets
Protection Devices	Outage Detection by: F-35 Relay Mitigation by: SEL 351 Relay	IED (N-60 Relay with Synchrophasor) IED (N-60 Relay with Synchrophasor)
System Monitoring, Arming, and Mitigation Computation	Grid Control Center – EMS (Energy Management System) Computer with manual “first” level of arming and disabling	Central Controller High Performance Dell Processors with GOOSE analytic and computational tools for automated arming with Operator RAS disabling capabilities
Data scan Interval	Every 4 <u>seconds</u> (EMS Link)	Every <u>100 msec</u> (setup parameter)
Data historian	EMS Alarm Summaries, Sequential Event Recorders	OSISoft PI Historian Software

Layout of the C-RAS Scheme Concept With Emerging Telecomm/Protection Technologies

I. Monitoring & Detection

1. Line flow monitoring
2. Line outage detection

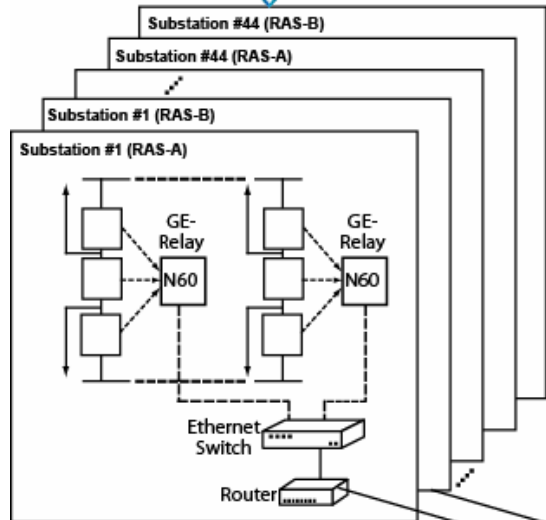

II. RAS Logic Processing

1. Arming Calculations & logic checks
2. Mitigation Level Calculations

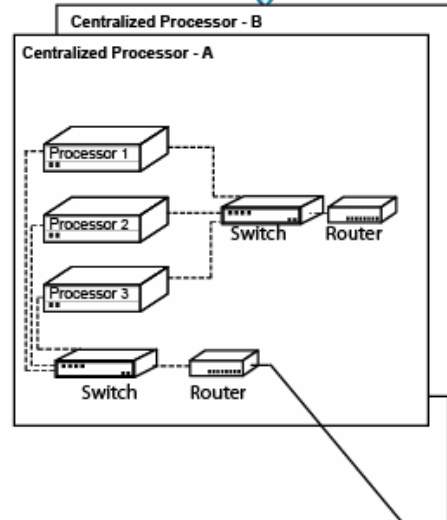

III. Mitigation

1. Generation/load level monitoring
2. Generation tripping/load shedding

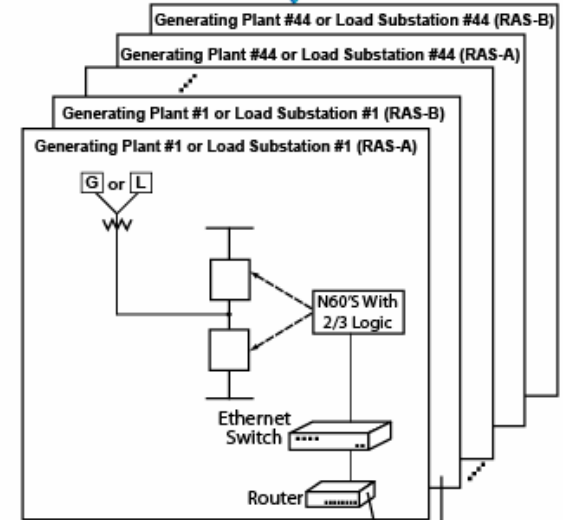

Telecomm/Protection Technologies

- Use of IEC 61850 "Goose" standard over SCE Area Network (WAN) with Ethernet switches/routers
- Use of N-60 relays (GE or other) for line outage detection & mitigation signal delivery
- Use of Central Controller – High Performance DELL Computing Processors

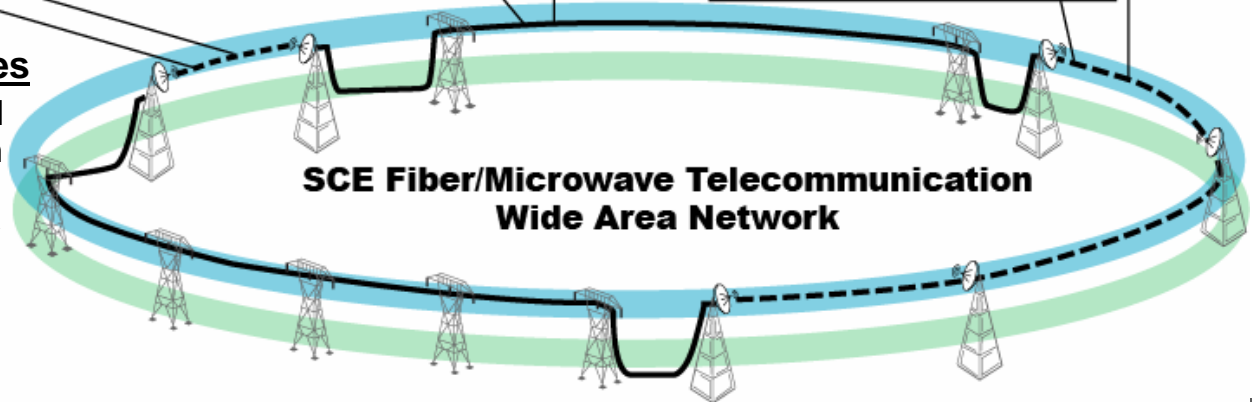

C-RAS Full Deployment

(South of Lugo RAS shown under C-RAS Deployment with Redundancy)

LOAD MONITORING & MITIGATION BY LOAD SHEDDING

MONITORING & DETECTION IEDs

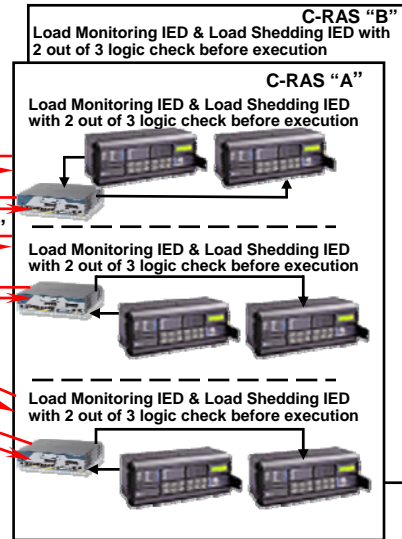
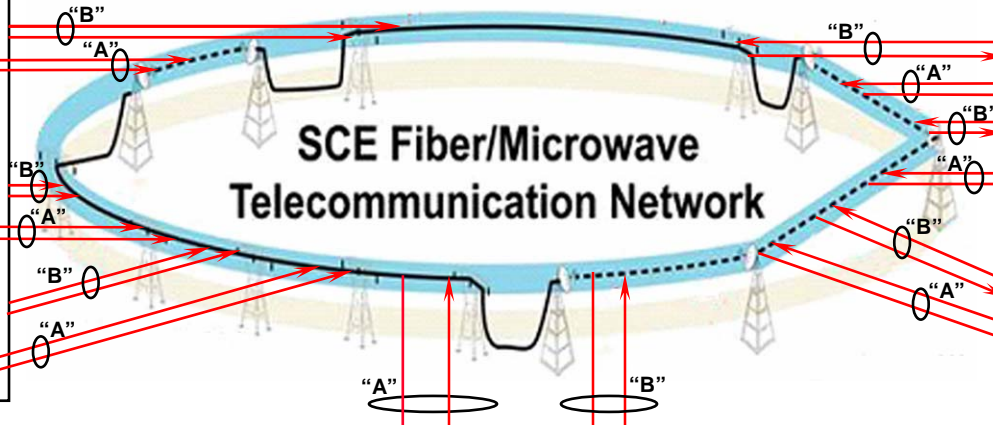
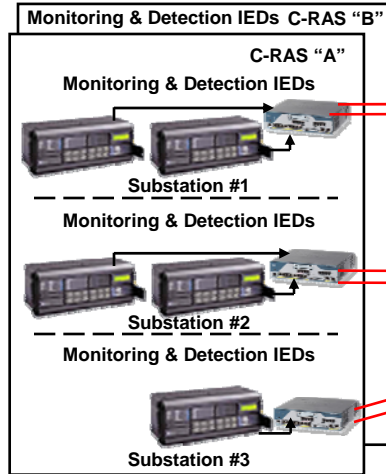

C-RAS "B" Controller Setup with triple redundant Processors at Secondary Secure Location

C-RAS "A" Controller Setup with triple redundant Processors at Grid Control Center

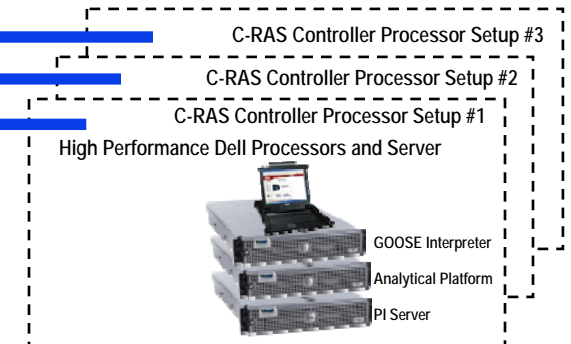
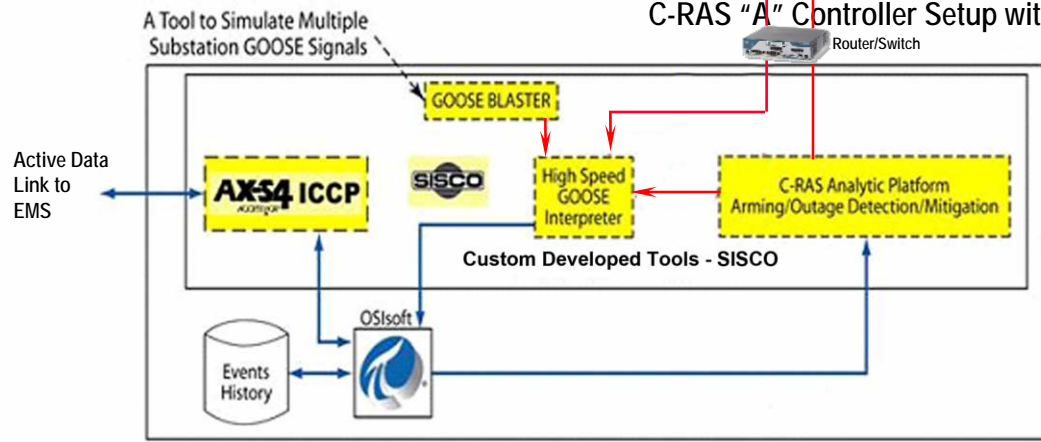

Pilot C-RAS Controller equipment to be moved to Grid Control Center

Data Flow Diagram for GOOSE and other data

(All displayed tools reside and execute in the C-RAS Controller Dell Processors and Server shown on the right)

C-RAS Pilot Test Results

C-RAS Components	Phase 1	Phase 2	Phase 3	Phase 3a	Phase 3b	Achieving Full Operational Deployment (2009-2011)
	Feb. 2006	Aug. 2006	Dec. 2007	Apr. 2008	Oct. 2008	
Line Flows and Arming Source						
• N-60 Synchrophasers & Controller				X	X	X
Event Detection Relays Location						
• Smart Grid Lab Setup	X	X	X			
• Substations				X	X	X
Mitigation Relay Location						
• Smart Grid Lab Setup	X	X	X	X		
• Field Substation "Proxy"					X	
• Field Substation "Real" Mitigation						X
C-RAS Controller						
• N-60 Relay	X					
• Off-the-shelf products (SISCO)		X				
• Customized products (SISCO)			X	X	X	X
C-RAS Controller Location						
• Smart Grid Lab Setup	X	X	X	X		
• Grid Control Center					X	X
OSIsoft C-RAS Controller SW						
• Off-the-shelf		X				
• Optimized			X	X	X	X
EMS Link						
• Operator Control						X
Other						
• Redundancy						X
• Demarcation			X	X	X	X
Performance Speed Results (msec)	22	40	11.4-16.7	12.48		

*The Performance Speed Results include the time for detecting the outage, RAS Processing and Mitigation Signal Delivery to load tripping relays.

Next Steps

- **Work on NERC CIP Compliance Issues**
- **Secure final WECC RAS Task Force approval; preliminary approval granted April '08. Action items from last meeting:**
 - Final testing plan presentation to WECC RAS Reliability Subcommittee
 - EMS grid operator C-RAS display screen
- **Present C-RAS Platform to CAISO for Approval in Annual Assessment Process**
- **Publish Project Summary with detailed scope, schedule and cost for full implementation**
 - Subject to GRC Approval of funds
- **Secure funding and resource approvals internally**

Conclusions

- **SCEnet, IEC61850, IEDs and Dell Processors combine to enable the next revolutionary step for the electric utility**